

DD104-7

Ver. 1 Rel. 03/22/06

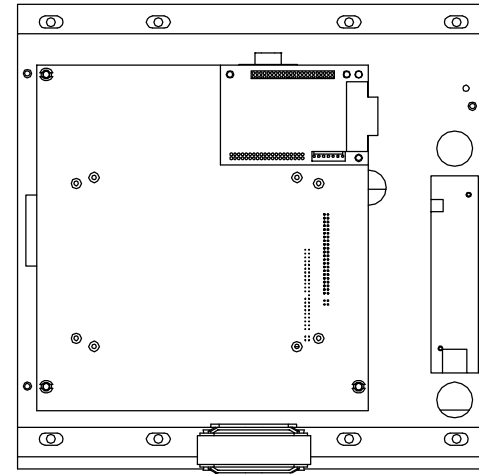
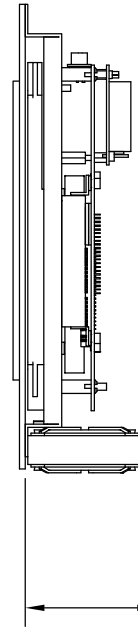
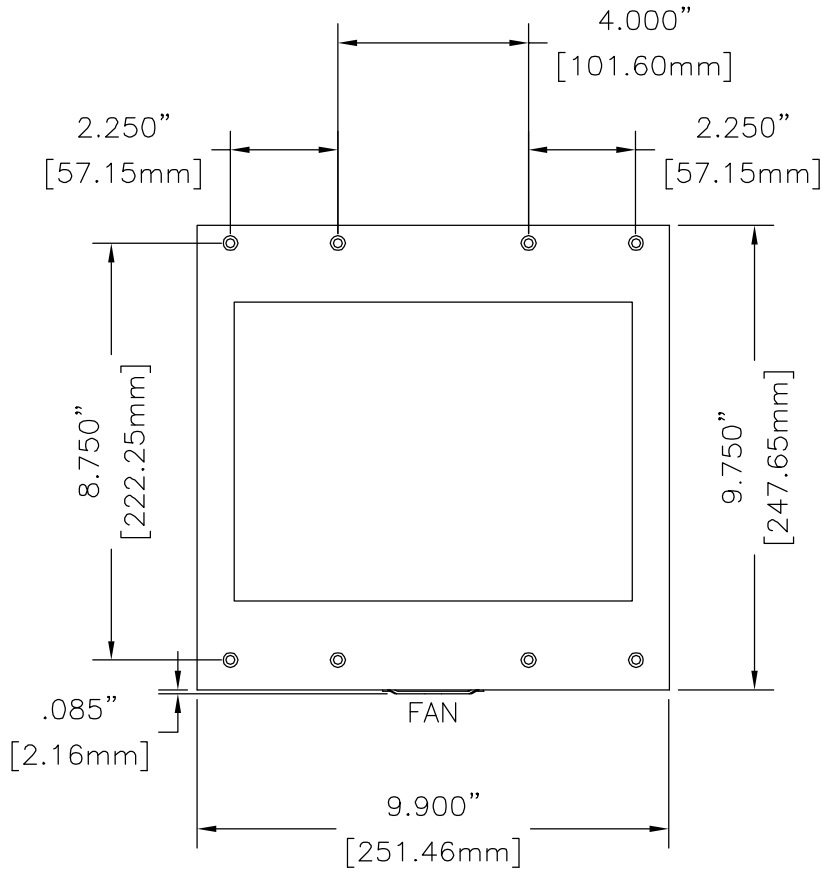

LENS NUMBER:	BOARD # & REV:
APPROVED BY:	
Signature: _____	
Date: _____	
Company: _____	

DATE DRAWN: 3/22/06	LAST DATE REVISED	SCALE NONE	PART #:
DRAWN BY: D.W.S.	TOLERANCE UNLESS OTHERWISE SPECIFIED: +0.015, -0.015		C.E. ELECTRONICS, INC. 2107 Industrial Drive Bryan, Ohio 43506 (419) 636-6705
REQUESTED BY: T.E.	TOLERANCE FOR CUTOUT (WINDOW): +0.020, -0.000		
TITLE:	DWG. NO. DD104-7	REV:	