



# OX121-AK2

12.1" OTIS LUXURY PI SERIES - LIQUID CRYSTAL DISPLAY (LCD)



## OTIS

12.1" Luxury PI

The Otis Luxury PI is the most flexible position indicator available. With the Luxury layout software, you can customize your own position indicator by selecting background colors and textures, fonts, and arrow styles. This system is so flexible you can even determine where the display elements appear on the screen. In addition to design flexibility, the Otis Luxury PI can display floor, priority, and time-based messages.

### TYPICAL APPLICATIONS:

- > Car-op panel
- > Transom car
- > Hall

### FEATURES:

- > Passing chime output
- > Live video option
- > Self testing
- > Low profile
- > Luxury Designer software
- > Luxury Transfer software
- > Otis RSL Serial Link input



Otis Elevator Company

Newberry Road

Bloomfield, CT

Ph: 860.676.6000

Otis Worldwide

www.otisworldwide.com



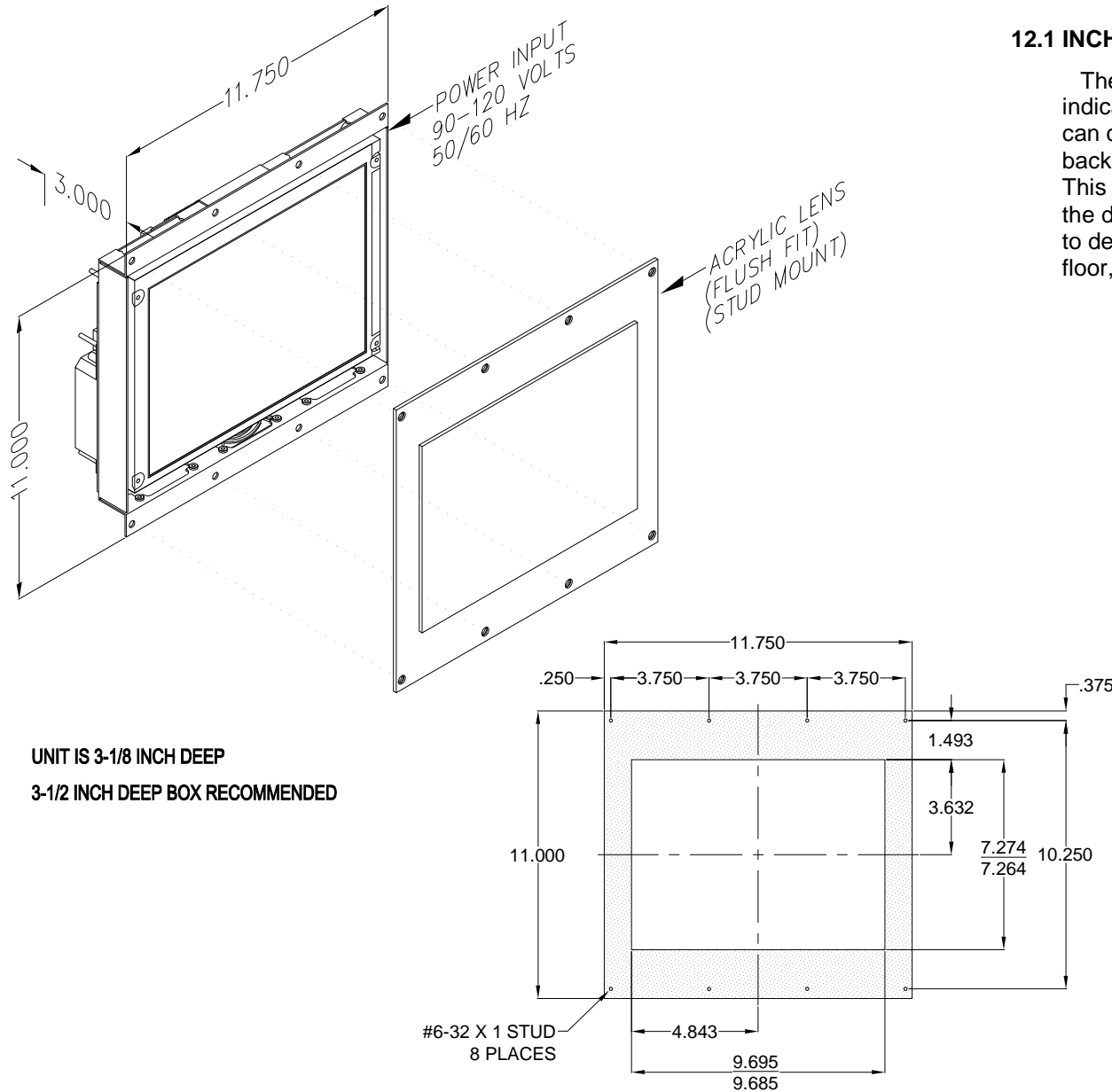

UNIT IS 3-1/8 INCH DEEP  
 3-1/2 INCH DEEP BOX RECOMMENDED

## 12.1 INCH LUXURY PI - LIQUID CRYSTAL DISPLAY (LCD)

The Otis Luxury PI is the most flexible position indicator available. With the Luxury layout software, you can customize your own position indicator by selecting background colors and textures, fonts, and arrow styles. This system is so flexible you can even determine where the display elements appear on the screen. In addition to design flexibility, the Otis Luxury PI can display floor, priority, and time-based messages.

### Typical Applications

- Car-op panel
- Transom car
- Hall

### Features:

- Passing chime output
- Live video option
- Self testing
- Low profile
- Elite designer software
- Elite transfer software
- Otis RSL Serial Link input

**TO ORDER: - OX121 - A K 2**

SERIES:

- "L" = MAIN
- "V" = VIDEO
- "A" = AUXILIARY PANEL LINK

### DRIVER OPTIONS:

USE OEMS-X ONLY IF 411 SYSTEM IS USING THE EMS OPTION  
 IF USING AN OEMS, PLEASE REFER TO EX121 MICRO COMM ELITE PAGE

RELATED DRAWINGS	
DESCRIPTION	DRAWING NAME
PANEL PREP.	PP121-1
DETAIL DIM.	DD121-1

# DD121-1

Ver. 2 Rel. 11/03/2014

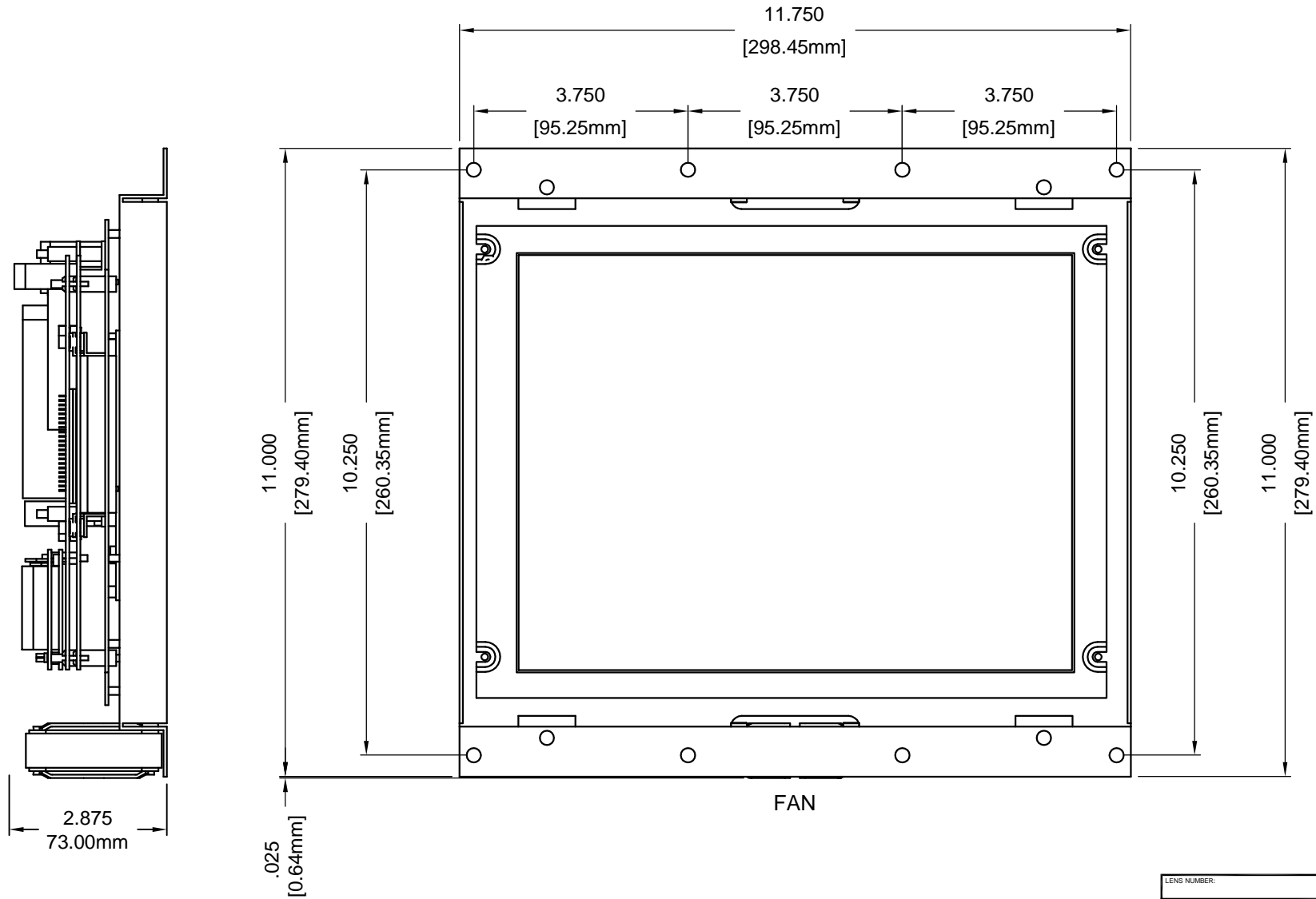

**NOTES:**

**STANDARD 12.1 TFT UNIT:**

Recommended minimum depth with basic unit of at least 3.00" with a standard 1/8" step lens.

LENS NUMBER:	BOARD # & REV:
APPROVED BY:	
Signature: _____	
Date: _____	
Company: _____	

DATE DRAWN: 4/11/07	LAST DATE REVISED 11/03/2014	SCALE NONE	PART #
DRAWN BY: DWS	TOLERANCE UNLESS OTHERWISE SPECIFIED: ±.015		 C.E. ELECTRONICS, INC. 2107 Industrial Drive Bryan, Ohio 43506 (419) 636-6705
REQUESTED BY: TE	TOLERANCE FOR CUTOUT (WINDOW):		
TITLE: DD121-1 DRAWING			DWG. NO. DD121-1
			REV:

# PP121-1

Ver. 1 Rel. 07/21/06

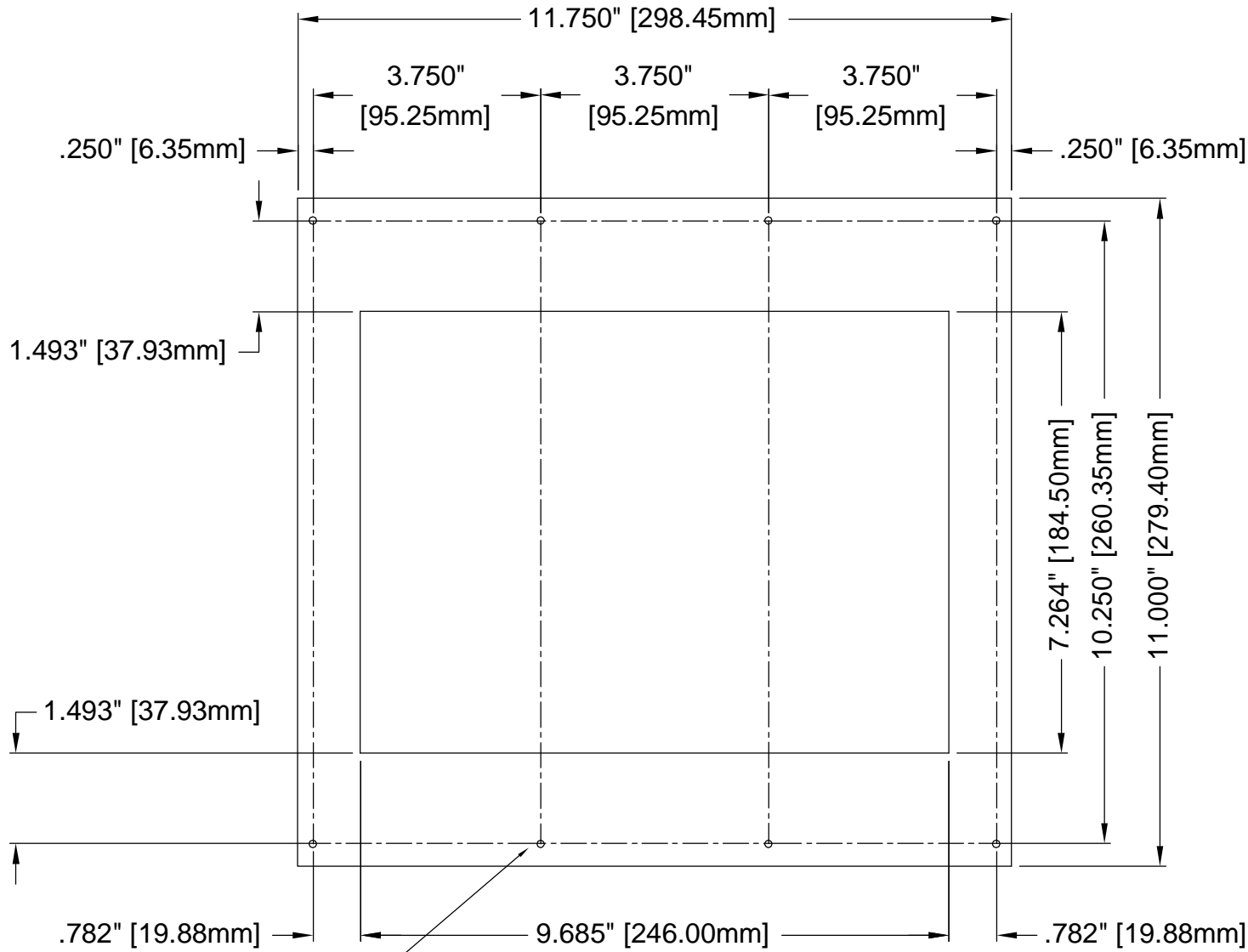

#6-32 X 3/4" STUD MIN.  
(TYPICAL 8 PLACES)

LENS NUMBER:	BOARD # & REV:
APPROVED BY:	
Signature: _____	
Date: _____	
Company: _____	

DATE DRAWN: 7/21/06	LAST DATE REVISED:	SCALE: NONE	PART #:
DRAWN BY: D.W.S.	TOLERANCE UNLESS OTHERWISE SPECIFIED: +0.015, -0.015		C.E. ELECTRONICS, INC. 2107 Industrial Drive Bryan, Ohio 43506 (419) 636-6705
REQUESTED BY: T.E.	TOLERANCE FOR CUTOUT (WINDOW): +0.020, -0.000		
TITLE: PP-121-1 DRAWING			DWG. NO. PP121-1 & DD121-1
			REV:

# OTIS MAIN TFT

\* - ITEMS INSTALLED ON VIDEO VERSION ONLY

JOB# \_\_\_\_\_

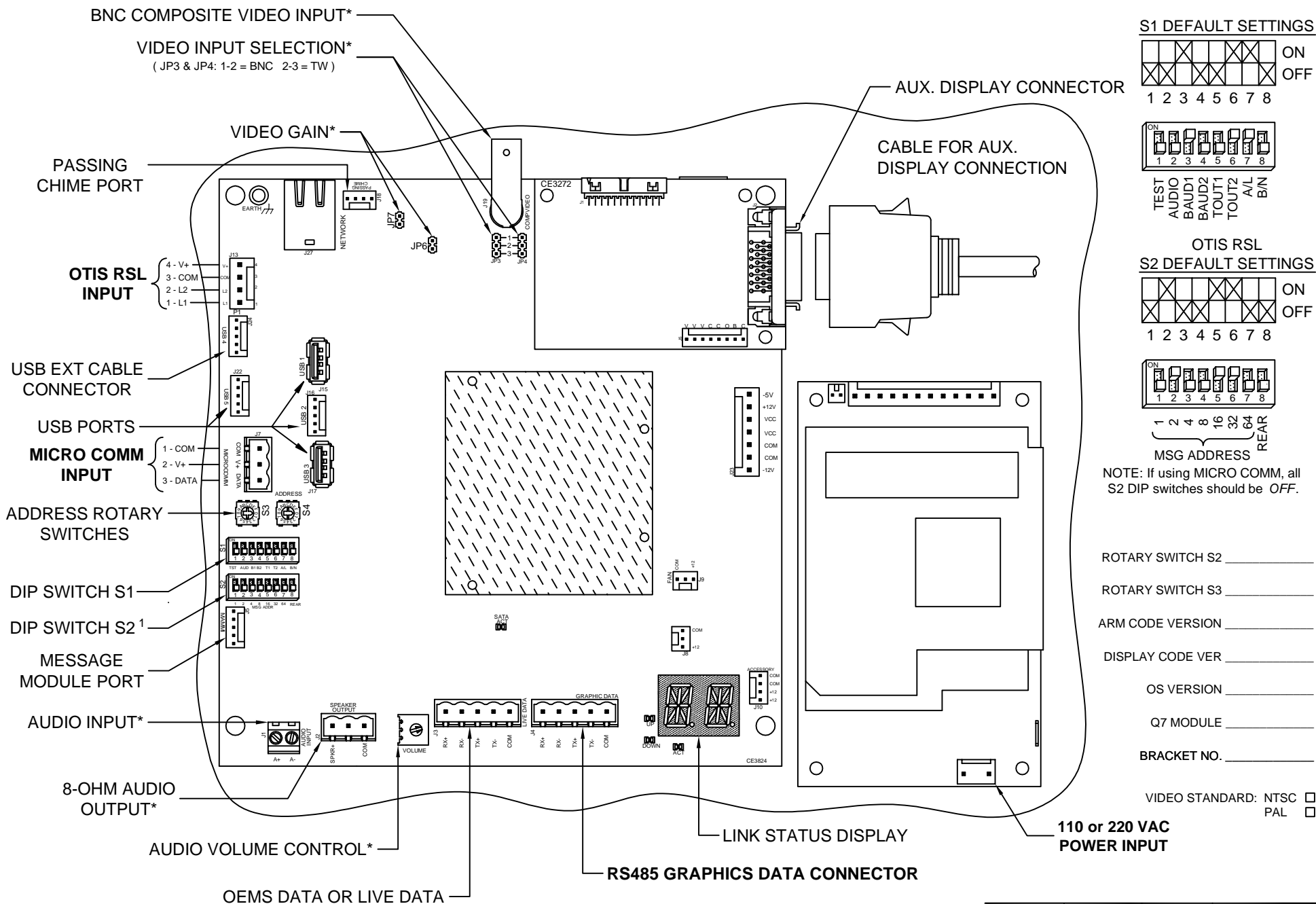

## S1 DEFAULT SETTINGS

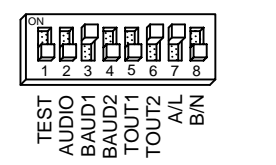
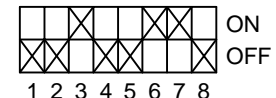

## OTIS RSL

### S2 DEFAULT SETTINGS

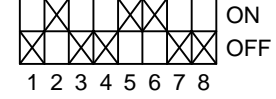

NOTE: If using MICRO COMM, all S2 DIP switches should be OFF.

ROTARY SWITCH S2 \_\_\_\_\_

ROTARY SWITCH S3 \_\_\_\_\_

ARM CODE VERSION \_\_\_\_\_

DISPLAY CODE VER \_\_\_\_\_

OS VERSION \_\_\_\_\_

Q7 MODULE \_\_\_\_\_

BRACKET NO. \_\_\_\_\_

VIDEO STANDARD: NTSC   
PAL

<sup>1</sup> S2 FUNCTIONS CHANGE BASED ON RSL OR MICRO COMM USE.

DATE DRAWN: 02/24/16	DRAWN BY: DAC	REQUESTED BY: TE	C.E. ELECTRONICS, INC. 2107 Industrial Drive Bryan, Ohio 43306 (419) 636-6705
BOARD NUMBER: 3824, 3272	LAST DATE REVISED: -	APPROVED BY: -	
PRODUCT: OTIS ELITE PI MAIN - LVDS			
DWG. NO. 104TFTBACK_3824_RSL REV: -			

## S1 DIP SWITCH SETTINGS

### DIP Switch 1 - Test Mode

Off = Normal Run Mode  
 On = The display will cycle up and down through all programmed floors (Front Side Only).

### DIP Switch 2 - Audio Output

Off = Audio Software Controlled  
 On = Audio Enabled

### DIP Switch 4, 3 - RS485 Configuration Link Baud Rate (Must match Transfer Program)

DS4	DS3	BAUD RATE
OFF	OFF	9600
OFF	ON	19200 (Default)
ON	OFF	38400
ON	ON	57600

### DIP Switch 6, 5 - Watchdog Period (Length of time the PIC waits for a response from Elite Display before resetting the display)

DS6	DS5	Wait Period
OFF	OFF	One Minute
OFF	ON	Two Minutes
ON	OFF	Three Minutes (Default)
ON	ON	Never Reset Display

### DIP Switch 7 - Converter Board Display Mode (does not affect TFT screen)

Off = Scan Slot Data Displayed  
 On = ASCII Data Displayed

NOTE: Left Cube Dot = Priority Message Sent  
 Right Cube Dot = Door Strobe Active

### DIP Switch 8 - Single/Multi-Car

Off = Single Car - Standard MICRO COMM Links  
 On = Multi-Car - Special 8-to-1 MICRO COMM Links Only!

## ROTARY SWITCH SETTINGS

Rotary Switch S3 - Used for USB transfers. Default setting is 0.

Rotary Switch S4 - Unit Address

This switch sets the address of the Elite PI unit. The default is address 1, which is switch setting 0.

NOTE: This address must match the Transfer program setting.

S4	Unit Address	S4	Unit Address	S4	Unit Address	S4	Unit Address
0	1	4	5	8	9	C	13
1	2	5	6	9	10	D	14
2	3	6	7	A	11	E	15
3	4	7	8	B	12	F	16

### MICRO COMM LINK (18-GAUGE WIRE)

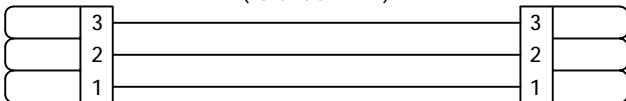

### SMARTMUX to ELITE PI and (if needed) to ELITE PI

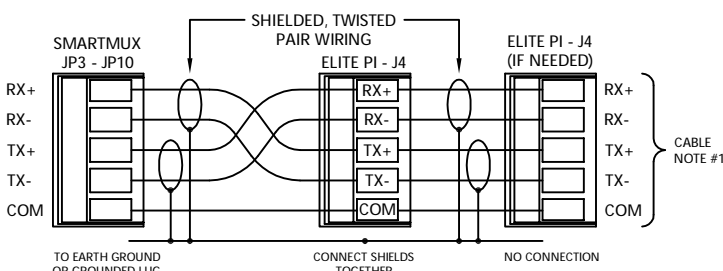

NOTE: Shields **MUST** be grounded to controller/earth ground lug

## S2 DIP SWITCH SETTINGS - when using MICRO COMM input

ARRIVAL ARROWS & DESTINATIONS DS1 - DS7 set the unit's floor number.

DS7 (64)	DS6 (32)	DS5 (16)	DS4 (8)	DS3 (4)	DS2 (2)	DS1 (1)	FLOOR NUMBER
OFF	OFF	OFF	OFF	OFF	OFF	OFF	CAR UNIT
OFF	OFF	OFF	OFF	OFF	OFF	ON	FLOOR 1
OFF	OFF	OFF	OFF	OFF	ON	OFF	FLOOR 2
OFF	OFF	OFF	OFF	OFF	ON	ON	FLOOR 3
:	:	:	:	:	:	:	:
:	:	:	:	:	:	:	:
ON	ON	ON	ON	ON	OFF	ON	FLOOR 125
ON	ON	ON	ON	ON	ON	OFF	FLOOR 126
ON	ON	ON	ON	ON	ON	ON	NOT USED

Switch 8 sets the unit as front or rear. DS8 OFF - Front Unit DS8 ON - Rear Unit

### VIDEO TEST MODE

Video test mode uses a combination of DIP switch and rotary switch settings. Please write down the initial setting of the S3 and S4 rotary switches before starting this process.

#### Entering Video Test Mode

Set DIP switch 1 to OFF, then set S3 and S4 to position F. Next, set DIP switch 1 to ON. The Live Video Adjustment menu will appear on the screen with Brightness highlighted.

#### Choosing Item to Adjust

The highlighted item is the current selection. To choose a different item to adjust, set S3 as shown below:

S3	Adjustment	S3	Adjustment
F	Brightness	B	Video Standard
E	Contrast	A	Vertical Stretch
D	Color	9	Default
C	Tint	8	Original

### Making Adjustments

Highlight the item to change and turn S4 for the best display quality.

#### Default and Original Settings

Default resets the display to the factory default settings. Original cancels any changes made and restores the values stored before entering Video Test mode. Highlight the item to use, turn S4 in either direction, and wait five seconds. The display will reset to the default or previous settings.

#### Exiting Video Test Mode

To save the new video settings and exit Video Test, set DIP switch 1 to OFF. Reset S3 and S4 to the values recorded before starting the process.

### Video Gain

JP7 and JP6 control the video gain. Use a shunt to short the pins of the jumpers as shown in the table below (OFF = No Shunt, ON = Shunt):

JP7	JP6	VIDEO GAIN
OFF	OFF	No Gain (Default)
OFF	ON	Lowest Gain
ON	OFF	
ON	ON	Highest Gain

### Adjusting Audio Volume

If you need audio, connect an 8-ohm speaker to J2 on the Elite PI board. Set the volume by adjusting Volume pot R2 (3/4 turn pot). Adjust the pot clockwise to increase the volume.

### CABLE NOTES:

- 1) Use shielded, twisted pair wires. We recommend using 24-gauge or larger wires. NOTE: Connect shields to controller/earth ground.
- 2) Use one wire of a twisted pair or a separate wire for common.
- 3) The audio input cable should be a shielded, twisted pair cable.
- 4) BNC composite video cable - 75 ohm RG6 recommended.
- 5) Twisted pair video cable - Unshielded twisted-pair wire recommended Baluns required - C.E.# V23501P02

DATE DRAWN: 02/24/16	DRAWN BY: DAC	REQUESTED BY: TE	 C.E. ELECTRONICS, INC. 2107 Industrial Drive Bryan, OH 43306 (419) 636-6705
BOARD NUMBER: 3824	LAST DATE REVISED: 10/09/17	APPROVED BY:	
PRODUCT CE3824 Otis TFT Setup Information			DWG. NO. CE3824RSL_SETUP REV. B

The serial link must contain the following Otis data at the specified addresses for the display to work properly. Select the RSL Data address by setting S2, DIP switches 1-6 using the binary number for the desired address. The board reads five continuous addresses beginning with the address determined by the DIP switch setting. For example, if the DIP switch is set to address 50 (default), the board reads the bits at addresses 50-54.

DIP switch address - selected by the S2 DIP switch on the unit (Default 50):

Bit 1 - FDO	Front Door Open	>>>>>>	Either of these will activate the play voice strobe,
Bit 2 - RDO	Rear Door Open	>>>>>>	but also control which lantern inputs are read.
Bit 3 - Not Used			
Bit 4 - LPT	Landing Passing Tone		Passing Chime

DIP switch address +1 (Default 51):

Bit 3 - CUML	Car Up Motion Lamp	Travel Up Arrow
Bit 4 - CDML	Car Down Motion Lamp	Travel Down Arrow

DIP switch address +2 (Default 52):

		<u>Priority</u>
Bit 1 - SESL	Fire Hat Jewel in COP	1
Bit 2 - FSL/RFSL	Fire Service Lamp	2
Bit 3 - FNDG/RNDG	Front/Rear Nudging	3
Bit 4 - ISCL	Independent Service Lamp	4

DIP switch address +3 (Default 53):

Bit 1 - OLS	Overload Lamp	5
Bit 2 - Available	Message Six	6
Bit 3 - Available	Message Seven	7
Bit 4 - Available	Message Eight	8

DIP switch address +4 (Default 54):

Bit 3 and Bit 4 contain Lantern UP and Lantern DOWN data when the arrival arrow address on S3 is set to zero and S2 DIP switches 7 & 8 are set to *OFF*.

To get the arrival data from a different address, use rotary switch S3 and S2 DIP switches 7 & 8. Rotary switch S3 provides the four lowest bits and S2 DIP switches 7 & 8 provide the highest two bits of a 6-bit address. For example, to use address 20, set rotary switch S3 to 4 and set S2 DIP switch 7 (16) to *ON* ( $4 + 16 = 20$ ). To use address 44, set rotary switch S3 to C (12) and set S2 DIP switch 8 (32) to *ON* ( $12 + 32 = 44$ ). The unit reads bits 3 & 4 of the designated address to determine the arrival data.

NOTE: At DIP switch address +1 and +4, bits 1 and 2 are not used. Also, the messages listed at DIP switch address +2 and +3 are the default messages, but any signal can be used to trigger a message at the corresponding bit location.

For destination-based systems, please contact C.E. Electronics Customer Service (419-636-6705) for more information.