

# OVCTS

JOB# \_\_\_\_\_

## CHART TO SELECT ADDRESS WITH DIP SWITCH

VALUE	32	16	8	4	2	1	
DIP SWITCH #	7	6	5	4	3	2	ADDRESS
0	0	0	0	0	0	0	INVALID
0	0	0	0	0	0	0	INVALID
0	0	0	0	0	0	0	INVALID
0	0	0	0	0	0	0	INVALID
0	0	0	1	0	0	0	ADDRESS #4
0	0	0	1	0	1	0	ADDRESS #5
0	0	0	1	1	0	0	ADDRESS #6
0	0	0	1	1	1	0	ADDRESS #7
0	0	1	0	0	0	0	ADDRESS #8
0	0	1	0	0	1	0	ADDRESS #9
0	0	1	0	1	0	0	ADDRESS #10
0	0	1	0	1	1	0	ADDRESS #11
0	0	1	1	0	0	0	ADDRESS #12
0	0	1	1	0	1	0	ADDRESS #13
0	0	1	1	1	1	0	ADDRESS #14
0	0	1	1	1	1	1	ADDRESS #15
0	1	0	0	0	0	0	ADDRESS #16
0	1	0	0	0	1	0	ADDRESS #17
0	1	0	0	1	0	0	ADDRESS #18
0	1	0	0	1	1	0	ADDRESS #19
0	1	0	1	0	0	0	ADDRESS #20
0	1	0	1	0	1	0	ADDRESS #21
0	1	0	1	1	0	0	ADDRESS #22
0	1	0	1	1	1	0	ADDRESS #23
0	1	1	0	0	0	0	ADDRESS #24
0	1	1	0	0	1	0	ADDRESS #25
0	1	1	0	1	0	0	ADDRESS #26
0	1	1	0	1	1	0	ADDRESS #27
0	1	1	1	0	0	0	ADDRESS #28
0	1	1	1	0	1	0	ADDRESS #29
0	1	1	1	1	0	0	ADDRESS #30
0	1	1	1	1	1	0	ADDRESS #31
1	0	0	0	0	0	0	ADDRESS #32
1	0	0	0	0	1	0	ADDRESS #33
1	0	0	0	1	0	0	ADDRESS #34
1	0	0	0	1	1	0	ADDRESS #35
1	0	0	1	0	0	0	ADDRESS #36
1	0	0	1	0	1	0	ADDRESS #37
1	0	0	1	1	0	0	ADDRESS #38
1	0	0	1	1	1	0	ADDRESS #39
1	0	1	0	0	0	0	ADDRESS #40
1	0	1	0	0	1	0	ADDRESS #41
1	0	1	0	1	0	0	ADDRESS #42
1	0	1	0	1	1	0	ADDRESS #43
1	0	1	1	0	0	0	ADDRESS #44
1	0	1	1	0	1	0	ADDRESS #45
1	0	1	1	1	0	0	ADDRESS #46
1	0	1	1	1	1	0	ADDRESS #47
1	1	0	0	0	0	0	ADDRESS #48
1	1	0	0	0	1	0	ADDRESS #49
1	1	0	0	1	0	0	ADDRESS #50
1	1	0	0	1	1	0	ADDRESS #51
1	1	0	1	0	0	0	ADDRESS #52
1	1	0	1	0	1	0	ADDRESS #53
1	1	0	1	1	0	0	ADDRESS #54
1	1	0	1	1	1	0	ADDRESS #55
1	1	1	0	0	0	0	ADDRESS #56
1	1	1	0	0	1	0	ADDRESS #57
1	1	1	0	1	0	0	ADDRESS #58
1	1	1	0	1	1	0	ADDRESS #59
1	1	1	1	0	0	0	ADDRESS #60
1	1	1	1	0	1	0	ADDRESS #61
1	1	1	1	1	0	0	ADDRESS #62
1	1	1	1	1	1	0	ADDRESS #63

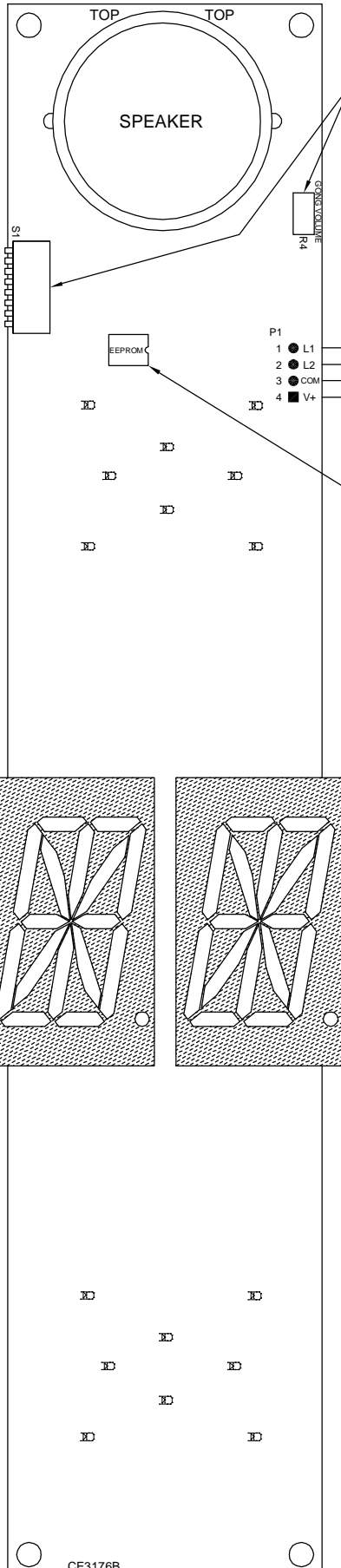

GONG VOLUME CONTROL AND DIP SWITCH ARE RIGHT-ANGLE DEVICES AND ARE MOUNTED ON THE FRONT OF THE BOARD.

OTIS SERIAL CONTROLLER CONNECTION

BLUE  
WHITE  
BLACK  
RED

EEPROM IS USED TO DISPLAY DIFFERENT CHARACTERS THAN ARE RECEIVED. USE "OCDL.EXE" PROGRAM TO CREATE EEPROM DATA.

### DIP SWITCH DETAIL

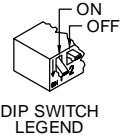
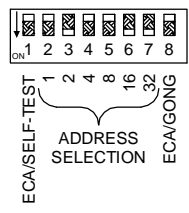

### DEFAULT SETTINGS

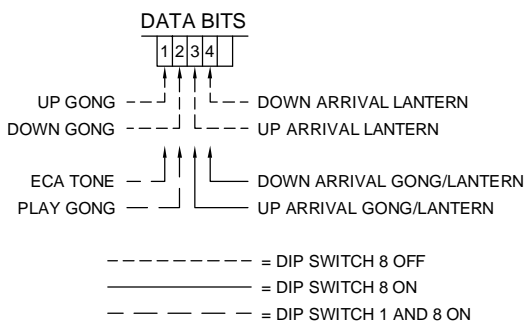
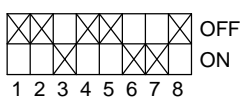

DIP1	DIP8	FUNCTION
1	0	SELF-TEST MODE
0	0	GONG USES BIT 1 UP (SINGLE) AND BIT 2 DOWN (DOUBLE)
0	1	GONG USES BIT 3 UP AND BIT 4 DOWN (BOTH SINGLE)
1	1	ECA MODE

CODE VERSION \_\_\_\_\_  
BOARD VERSION CE3176 \_\_\_\_\_

DATE DRAWN: 09/14/05	DRAWN BY: DAC	REQUESTED BY: MG, CS	C.E. ELECTRONICS, INC. 2107 Industrial Drive Bryan, Ohio 43006 (419) 636-6705
BOARD NUMBER: 3176	LAST DATE REVISED: -	APPROVED BY:	
PRODUCT: OVCTS-XXX	DWG. NO.: OVCTS 01	REV: -	

The following Otis data must be furnished at the specified addresses for the Otis Serial Indicator to work properly. The address is selected by setting DIP switches 2-7 as shown on the back of this page. The board reads the address determined by the DIP switch setting. For example, if the DIP switch is set to address 50, the board will read the bits at address 50.

At DIP switch address—selected by the DIP switch on the unit (Default 50):

### Normal Operation

DIP switch 1 puts the unit in self-test mode.

DIP switch 1 and DIP switch 8 OFF:

- Bit 1—Up Gong (Single)
- Bit 2—Down Gong (Double)
- Bit 3—Up Arrival Arrow/Lantern
- Bit 4—Down Arrival Arrow/Lantern

DIP switch 1 OFF and DIP switch 8 ON:

- Bit 1—Not Used
- Bit 2—Not Used
- Bit 3—Up Arrival Arrow/Lantern and Up Gong (Single)
- Bit 4—Down Arrival Arrow/Lantern and Down Gong (Single)

### ECA Operation

DIP switches 1 and 8 ON puts the unit in ECA Mode:

- Bit 1—ECA Tone
- Bit 2—Play Gong
- Bit 3—Up Arrival Arrow/Lantern (Single Gong)
- Bit 4—Down Arrival Arrow/Lantern (Double Gong)

The unit display can substitute different floor characters for the ones the controller sends, and it can switch between floor characters and ASCII characters for a message. To display alternative floor characters or messages, an EEPROM created using the OCDL.EXE program must be installed in the unit. Message characters alternate with floor characters every second.

Messages use the two addresses following the address set by the DIP switch.

DIP switch address +1 (Default 51): Priority

- |                 |                     |   |
|-----------------|---------------------|---|
| Bit 1—FSL/RFSL  | Fire Service Lamp   | 1 |
| Bit 2—Available | Message Two         | 2 |
| Bit 3—FNDG/RNDG | Front/Rear Nudging  | 3 |
| Bit 4—ISCL      | Independent Service | 4 |

DIP switch address +2 (Default 52):

- |                  |               |   |
|------------------|---------------|---|
| Bit 1—OLS        | Overload Lamp | 5 |
| Bit 2— Available | Message Six   | 6 |
| Bit 3— Available | Message Seven | 7 |
| Bit 4— Available | Message Eight | 8 |

NOTE: If messages are not programmed in the EEPROM, these two addresses are available for other devices, such as other position indicators.