

OV220-X

JOB# _____

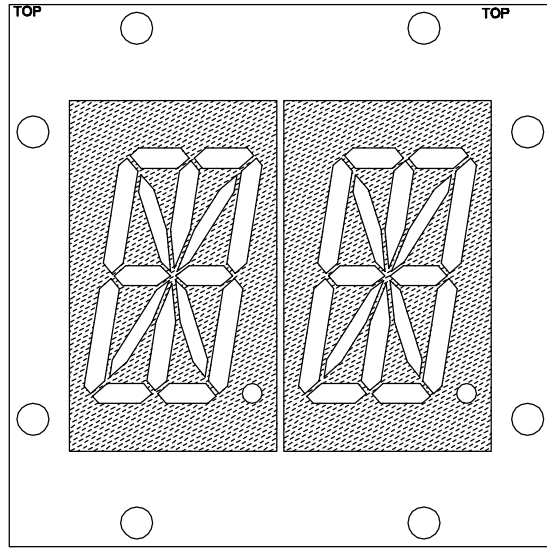
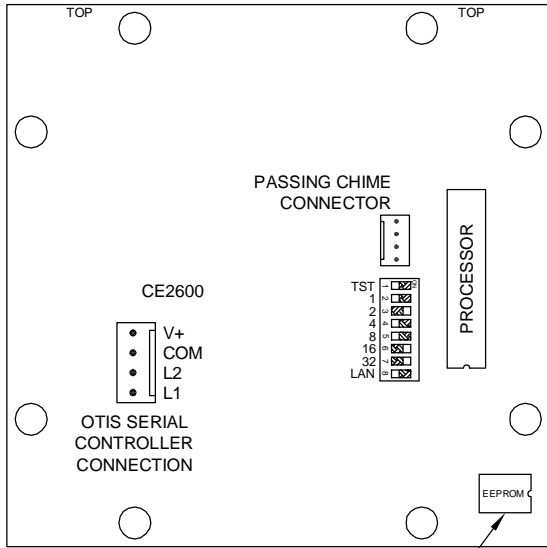

EEPROM IS USED TO DISPLAY DIFFERENT CHARACTERS THAN ARE RECEIVED. USE "OCDL.EXE" PROGRAM TO CREATE EEPROM DATA.

THE ARROWS APPEAR IN THE TENS DIGIT WHEN NO CHARACTER IS BEING DISPLAYED THERE. IF ARROWS ARE NOT REQUIRED, SET THE DIP SWITCHES TO AN ADDRESS LOWER THAN FOUR.

CHART TO SELECT ADDRESS WITH DIP SWITCH

DIP SWITCH DETAIL

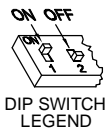
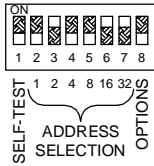

DEFAULT SETTINGS

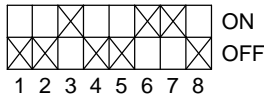

CODE VERSION _____

BOARD VERSION CE2600 _____

DATA BITS

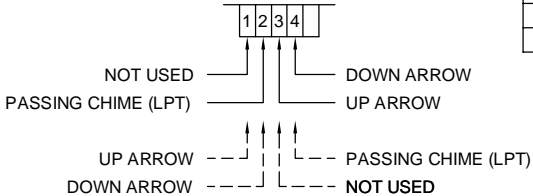

_____ = DIP SWITCH 8 OFF
 - - - - - = DIP SWITCH 8 ON

VALUE	32	16	8	4	2	1	ADDRESS
DIP SWITCH # 7	0	0	0	0	0	0	INVALID
DIP SWITCH # 6	0	0	0	0	0	0	INVALID
DIP SWITCH # 5	0	0	0	0	0	0	INVALID
DIP SWITCH # 4	0	0	0	0	0	0	INVALID
DIP SWITCH # 3	0	0	0	1	0	0	ADDRESS #4
DIP SWITCH # 2	0	0	0	1	0	1	ADDRESS #5
DIP SWITCH # 1	0	0	0	1	1	0	ADDRESS #6
DIP SWITCH # 0	0	0	0	1	1	1	ADDRESS #7
DIP SWITCH # 31	0	0	1	0	0	0	ADDRESS #8
DIP SWITCH # 30	0	0	1	0	0	1	ADDRESS #9
DIP SWITCH # 29	0	0	1	0	1	0	ADDRESS #10
DIP SWITCH # 28	0	0	1	0	1	1	ADDRESS #11
DIP SWITCH # 27	0	0	1	1	0	0	ADDRESS #12
DIP SWITCH # 26	0	0	1	1	0	1	ADDRESS #13
DIP SWITCH # 25	0	0	1	1	1	0	ADDRESS #14
DIP SWITCH # 24	0	0	1	1	1	1	ADDRESS #15
DIP SWITCH # 23	0	1	0	0	0	0	ADDRESS #16
DIP SWITCH # 22	0	1	0	0	0	1	ADDRESS #17
DIP SWITCH # 21	0	1	0	0	1	0	ADDRESS #18
DIP SWITCH # 20	0	1	0	0	1	1	ADDRESS #19
DIP SWITCH # 19	0	1	0	1	0	0	ADDRESS #20
DIP SWITCH # 18	0	1	0	1	0	1	ADDRESS #21
DIP SWITCH # 17	0	1	0	1	1	0	ADDRESS #22
DIP SWITCH # 16	0	1	0	1	1	1	ADDRESS #23
DIP SWITCH # 15	0	1	1	0	0	0	ADDRESS #24
DIP SWITCH # 14	0	1	1	0	0	1	ADDRESS #25
DIP SWITCH # 13	0	1	1	0	1	0	ADDRESS #26
DIP SWITCH # 12	0	1	1	0	1	1	ADDRESS #27
DIP SWITCH # 11	0	1	1	1	0	0	ADDRESS #28
DIP SWITCH # 10	0	1	1	1	0	1	ADDRESS #29
DIP SWITCH # 9	0	1	1	1	1	0	ADDRESS #30
DIP SWITCH # 8	0	1	1	1	1	1	ADDRESS #31
DIP SWITCH # 7	1	0	0	0	0	0	ADDRESS #32
DIP SWITCH # 6	1	0	0	0	0	1	ADDRESS #33
DIP SWITCH # 5	1	0	0	0	1	0	ADDRESS #34
DIP SWITCH # 4	1	0	0	0	1	1	ADDRESS #35
DIP SWITCH # 3	1	0	0	1	0	0	ADDRESS #36
DIP SWITCH # 2	1	0	0	1	0	1	ADDRESS #37
DIP SWITCH # 1	1	0	0	1	1	1	ADDRESS #38
DIP SWITCH # 0	1	0	0	1	1	1	ADDRESS #39
DIP SWITCH # 31	1	0	1	0	0	0	ADDRESS #40
DIP SWITCH # 30	1	0	1	0	0	1	ADDRESS #41
DIP SWITCH # 29	1	0	1	0	1	0	ADDRESS #42
DIP SWITCH # 28	1	0	1	0	1	1	ADDRESS #43
DIP SWITCH # 27	1	0	1	1	0	0	ADDRESS #44
DIP SWITCH # 26	1	0	1	1	0	1	ADDRESS #45
DIP SWITCH # 25	1	0	1	1	1	0	ADDRESS #46
DIP SWITCH # 24	1	0	1	1	1	1	ADDRESS #47
DIP SWITCH # 23	1	1	0	0	0	0	ADDRESS #48
DIP SWITCH # 22	1	1	0	0	0	1	ADDRESS #49
DIP SWITCH # 21	1	1	0	0	1	0	ADDRESS #50
DIP SWITCH # 20	1	1	0	0	1	1	ADDRESS #51
DIP SWITCH # 19	1	1	0	1	0	0	ADDRESS #52
DIP SWITCH # 18	1	1	0	1	0	1	ADDRESS #53
DIP SWITCH # 17	1	1	0	1	1	0	ADDRESS #54
DIP SWITCH # 16	1	1	0	1	1	1	ADDRESS #55
DIP SWITCH # 15	1	1	1	0	0	0	ADDRESS #56
DIP SWITCH # 14	1	1	1	0	0	1	ADDRESS #57
DIP SWITCH # 13	1	1	1	0	1	0	ADDRESS #58
DIP SWITCH # 12	1	1	1	0	1	1	ADDRESS #59
DIP SWITCH # 11	1	1	1	1	0	0	ADDRESS #60
DIP SWITCH # 10	1	1	1	1	0	1	ADDRESS #61
DIP SWITCH # 9	1	1	1	1	1	0	ADDRESS #62
DIP SWITCH # 8	1	1	1	1	1	1	ADDRESS #63

DIP1	DIP8	FUNCTION
1	X	SELF-TEST MODE
0	0	ARROW USES BIT 3 (UP) AND BIT 4 (DOWN). CHIME USES BIT 2.
0	1	ARROW USES BIT 1 (UP) AND BIT 2 (DOWN). CHIME USES BIT 4.

The following Otis data must be furnished at the specified addresses for the Otis Serial Position Indicator to work properly. The address is selected by setting DIP switches 2-7 as shown on the back of this page. The board reads the address determined by the DIP switch setting. For example, if the DIP switch is set to address 50, the board will read the bits at address 50.

At DIP switch address—selected by the DIP switch on the unit (Default 50):

DIP switch 1 puts the unit in self-test mode.

DIP switch 1 and DIP switch 8 *OFF*:

- Bit 1—Not Used
- Bit 2—Passing Chime (LPT)
- Bit 3—Up Arrow
- Bit 4—Down Arrow

DIP switch 1 *OFF* and DIP switch 8 *ON*:

- Bit 1—Up Arrow
- Bit 2—Down Arrow
- Bit 3—Not Used
- Bit 4—Passing Chime (LPT)

Two position indicators can be used at the same address if the passing chime—LPT is not attached or programmed. Just set DIP switch 8 to opposite values on the two units.

The Otis SPI display can substitute different floor characters for the ones the controller sends, and it can switch between floor characters and ASCII characters for a message. To display alternative floor characters or messages, an EEPROM created using the *OCDL.EXE* program must be installed in the unit. Message characters alternate with floor characters every second.

Messages use the two addresses following the address set by the DIP switch.

DIP switch address +1 (Default 51): Priority

Bit 1—FSL	Fire Service Lamp	1
Bit 2—Available	Message Two	2
Bit 3—FNDG/RNDG	Front/Rear Nudging	3
Bit 4—ISCL	Independent Service	4

DIP switch address +2 (Default 52):

Bit 1—OLS	Overload Lamp	5
Bit 2—Available	Message Six	6
Bit 3—Available	Message Seven	7
Bit 4—Available	Message Eight	8

NOTE: If messages are not programmed in the EEPROM, these two addresses are available for other devices, such as other position indicators.