

# > OV105-XX

## OTIS 411 SERIES CONTROLLERS



# OTIS

## REMOTE DISPLAY INDICATOR "RDI"

Segmented LED, digital indicator for floor position display, as well as car direction. Any alphanumeric character can be displayed in either single or double digit floor designations.

### TYPICAL APPLICATIONS:

- > Hall stations
- > Lobby and security panels

### FEATURES:

- > Fast, 4-wire hookup
- > Passing chime available on this unit
- > Otis 411 car data link hook-up
- > No RS5 card needed

# OTIS

Otis Elevator Company

Newberry Road

Bloomfield, CT

Ph: 860.676.6000

## Otis Worldwide

[www.otisworldwide.com](http://www.otisworldwide.com)





C.E. Electronics, Inc.  
 2107 Industrial Drive  
 Bryan, OH 43506  
 PH (419) 636-6705 FX (419) 636-2516  
 www.ccelectronics.com

# OV105-XX

Ver. 5 Rel. 2/18/2019

OTIS

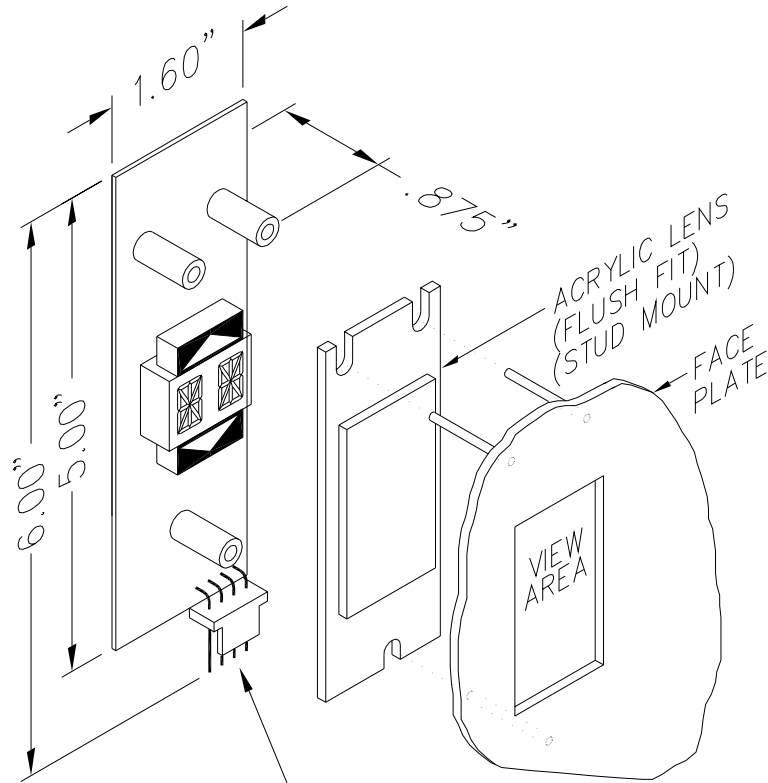

**INPUT CONNECTION**

OTIS CAR DATA LINK  
 L1, L2, P, G

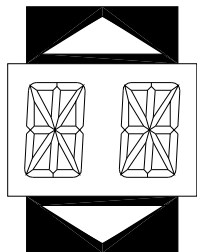

1/2" CHARACTER

**RENEWAL PARTS**

- Lens: 104-5605 RED
- Lens: 104-6005 GRAY
- Lens: 104-9005 BLUE

**PANEL PREPARATION**

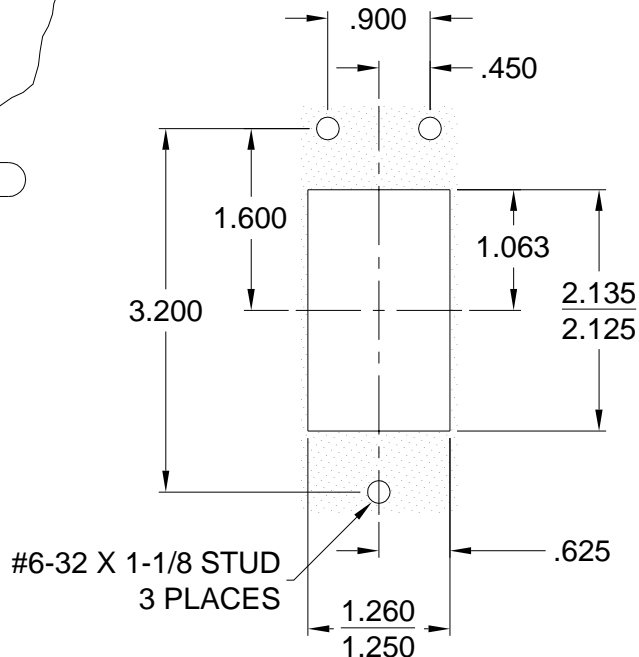

**OTIS 411 SERIES CONTROLLERS**

**REMOTE DISPLAY INDICATOR "RDI"**

Segmented LED, digital indicator for floor position display, as well as car direction. Any alphanumeric character can be displayed in either single or double digit floor designations.

Typical Applications

- Hall stations
- Lobby and security panels

Features:

- Fast, 4-wire hookup
- Passing chime available on this unit
- Otis 411 car data link hook-up
- No RS5 card needed

TO ORDER - SPECIFY OV105 - X X

**COLOR:**

- "R" = RED SEGMENTS / RED ARROWS
- "G" = GREEN SEGMENTS / RED ARROWS
- "B" = BLUE SEGMENTS / BLUE ARROWS

**LENS:**

- "R" = RED
- "G" = GRAY
- "B" = BLUE
- "X" = NO LENS

# OV105-XX

JOB# \_\_\_\_\_

## DEFAULT SETTINGS

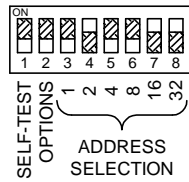
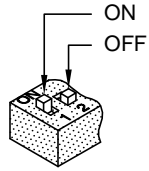
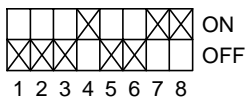

## CHART TO SELECT ADDRESS WITH DIP SWITCH

32	16	8	4	2	1 - VALUE	
DS8	DS7	DS6	DS5	DS4	DS3	ADDRESS
0	0	0	0	0	0	INVALID
0	0	0	0	0	0	INVALID
0	0	0	0	0	0	INVALID
0	0	0	0	0	0	INVALID
0	0	0	1	0	0	ADDRESS #4
0	0	0	1	0	1	ADDRESS #5
0	0	0	1	1	0	ADDRESS #6
0	0	0	1	1	1	ADDRESS #7
0	0	1	0	0	0	ADDRESS #8
0	0	1	0	0	1	ADDRESS #9
0	0	1	0	1	0	ADDRESS #10
0	0	1	0	1	1	ADDRESS #11
0	0	1	1	0	0	ADDRESS #12
0	0	1	1	0	1	ADDRESS #13
0	0	1	1	1	0	ADDRESS #14
0	0	1	1	1	1	ADDRESS #15
0	1	0	0	0	0	ADDRESS #16
0	1	0	0	0	1	ADDRESS #17
0	1	0	0	1	0	ADDRESS #18
0	1	0	0	1	1	ADDRESS #19
0	1	0	1	0	0	ADDRESS #20
0	1	0	1	0	1	ADDRESS #21
0	1	0	1	1	0	ADDRESS #22
0	1	0	1	1	1	ADDRESS #23
0	1	1	0	0	0	ADDRESS #24
0	1	1	0	0	1	ADDRESS #25
0	1	1	0	1	0	ADDRESS #26
0	1	1	0	1	1	ADDRESS #27
0	1	1	1	0	0	ADDRESS #28
0	1	1	1	0	1	ADDRESS #29
0	1	1	1	1	0	ADDRESS #30
0	1	1	1	1	1	ADDRESS #31
1	0	0	0	0	0	ADDRESS #32
1	0	0	0	0	1	ADDRESS #33
1	0	0	0	1	0	ADDRESS #34
1	0	0	0	1	1	ADDRESS #35
1	0	0	1	0	0	ADDRESS #36
1	0	0	1	0	1	ADDRESS #37
1	0	0	1	1	0	ADDRESS #38
1	0	0	1	1	1	ADDRESS #39
1	0	1	0	0	0	ADDRESS #40
1	0	1	0	0	1	ADDRESS #41
1	0	1	0	1	0	ADDRESS #42
1	0	1	0	1	1	ADDRESS #43
1	0	1	1	0	0	ADDRESS #44
1	0	1	1	0	1	ADDRESS #45
1	0	1	1	1	0	ADDRESS #46
1	0	1	1	1	1	ADDRESS #47
1	1	0	0	0	0	ADDRESS #48
1	1	0	0	0	1	ADDRESS #49
1	1	0	0	1	0	ADDRESS #50
1	1	0	0	1	1	ADDRESS #51
1	1	0	1	0	0	ADDRESS #52
1	1	0	1	0	1	ADDRESS #53
1	1	0	1	1	0	ADDRESS #54
1	1	0	1	1	1	ADDRESS #55
1	1	1	0	0	0	ADDRESS #56
1	1	1	0	0	1	ADDRESS #57
1	1	1	0	1	0	ADDRESS #58
1	1	1	0	1	1	ADDRESS #59
1	1	1	1	0	0	ADDRESS #60
1	1	1	1	0	1	ADDRESS #61
1	1	1	1	1	0	ADDRESS #62
1	1	1	1	1	1	ADDRESS #63

PASSING CHIME PORT ON BACK OF BOARD AVAILABLE ON REQUEST

EEPROM IS USED TO DISPLAY DIFFERENT CHARACTERS THAN ARE RECEIVED. USE "OCDL.EXE" PROGRAM TO CREATE EEPROM DATA.

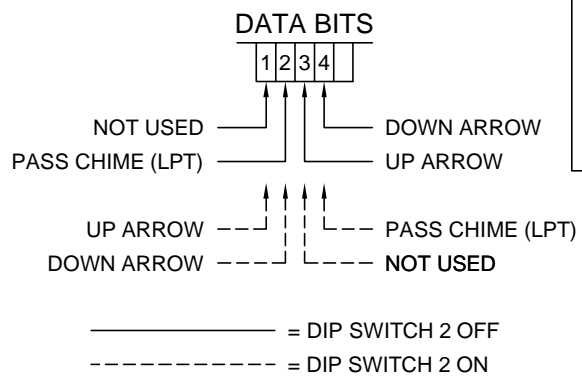
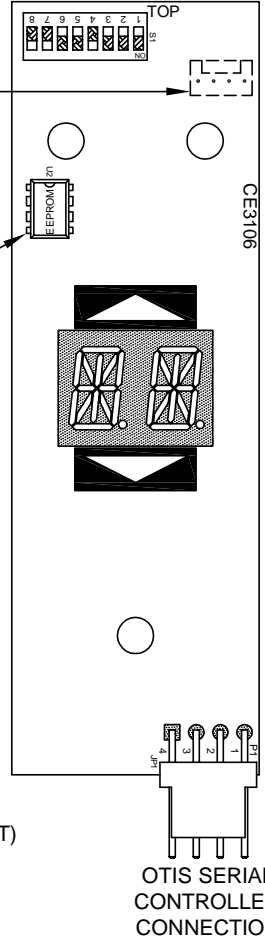

DIP1	DIP2	FUNCTION
1	X	SELF-TEST MODE
0	0	ARROW USES BIT 3 (UP) AND BIT 4 (DOWN). CHIME USES BIT 2.
0	1	ARROW USES BIT 1 (UP) AND BIT 2 (DOWN). CHIME USES BIT 4.

CODE VERSION \_\_\_\_\_

BOARD VERSION CE3106 \_\_\_\_\_

DATE DRAWN: 04/24/03	DRAWN BY: K.L.S.	REQUESTED BY: J.K.	C.E. ELECTRONICS, INC. 2107 Industrial Drive Bryan, Ohio 43306 (419) 636-6705
BOARD NUMBER: 3106	LAST DATE REVISED: 06/23/08	APPROVED BY:	
PRODUCT OV105-XX			

DWG. NO. OV105001-A    REV: F

The following Otis data must be furnished at the specified addresses for the Otis Serial Position Indicator to work properly. The address is selected by setting DIP switches 3-8 as shown on the back of this page. The board reads the address determined by the DIP switch setting. For example, if the DIP switch is set to address 50, the board will read the bits at address 50.

At DIP switch address—selected by the DIP switch on the unit (Default 50):

DIP switch 1 puts the unit in self-test mode.

DIP switch 1 and DIP switch 2 *OFF*:

- Bit 1—Not Used
- Bit 2—Passing Chime (LPT)
- Bit 3—Up Arrow
- Bit 4—Down Arrow

DIP switch 1 *OFF* and DIP switch 2 *ON*:

- Bit 1—Up Arrow
- Bit 2—Down Arrow
- Bit 3—Not Used
- Bit 4—Passing Chime (LPT)

Two position indicators can be used at the same address if the passing chime—LPT is not attached or programmed. Just set DIP switch 2 to opposite values on the two units.

The Otis SPI display can substitute different floor characters for the ones the controller sends, and it can switch between floor characters and ASCII characters for a message. To display alternative floor characters or messages, an EEPROM created using the *OCDL.EXE* program must be installed in the unit. Message characters alternate with floor characters every second.

Messages use the two addresses following the address set by the DIP switch.

DIP switch address +1 (Default 51):		<u>Priority</u>
Bit 1—450	Fire	1
Bit 2—FSL/RFSL	Fire Service Lamp	2
Bit 3—FNDG/RNDG	Front/Rear Nudging	3
Bit 4—ISCL	Independent Service	4
DIP switch address +2 (Default 52):		
Bit 1—OLS	Overload Lamp	5
Bit 2—Available	Message Six	6
Bit 3—Available	Message Seven	7
Bit 4—Available	Message Eight	8

NOTE: If messages are not programmed in the EEPROM, these two addresses are available for other devices, such as other position indicators.