



EX156W-AI2X

15.6" "WIDE" ELITE PI SERIES



ELITE PI

15.6" "WIDE" ELITE PI

The MICRO COMM Elite PI is the most flexible position indicator available. With the Elite PI Designer software, you can customize your own position indicator by selecting background colors and textures, fonts, and arrow styles. This system is so flexible you can even determine where the display elements appear on the screen. In addition to design flexibility, the MICRO COMM Elite PI can display floor, priority, and time-based messages.

TYPICAL APPLICATIONS:

- > Car operating panel
- > Car transom
- > Lobby

FEATURES:

- > HD @720P
- > Streaming View
- > Self Testing
- > Elite PI Designer software
- > Elite PI Transfer software
- > MICRO COMM serial link input



C.E. Electronics, Inc. (US) 2107 Industrial Drive, Bryan, Ohio 43506 p: 419.636.6705 www.cееlectronics.com

C.E. Electronics, Ltd. (UK) P.O. Box 1679 Marlow, Bucks SL7 3ZG, UK p: +44 (0) 1628 487633 www.cееlectronics.co.uk



C.E. Electronics, Inc.
 2107 Industrial Drive
 Bryan, OH 43506
 PH (419) 636-6705 FX (419) 636-2516
 www.ccelectronics.com

EX156W-AI2X

Ver. 1 Rel. 1/9/2023

ELITE PI[®]

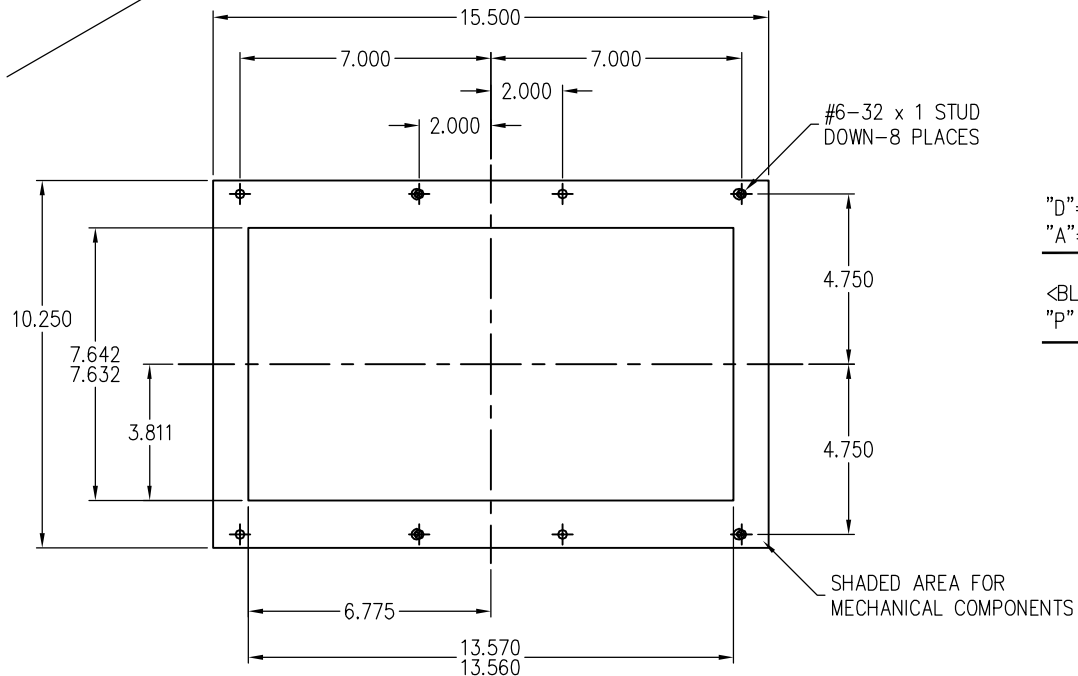
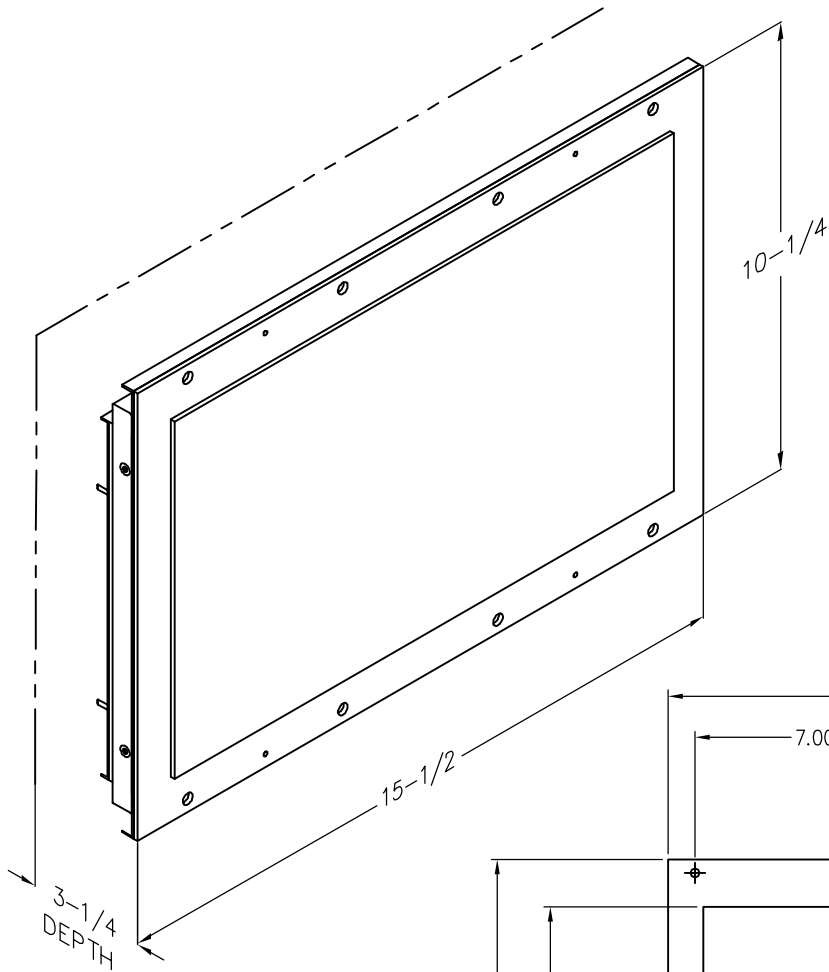

15.6 INCH "WIDE" Elite PI

The MICRO COMM Elite PI is the most flexible position indicator available. With the Elite PI Designer software, you can customize your own position indicator by selecting background colors and textures, fonts, and arrow styles. This system is so flexible you can even determine where the display elements appear on the screen. In addition to design flexibility, the MICRO COMM Elite PI can display floor, priority, and time-based messages.

Typical Applications

- Car operating panel
- Car transom
- Lobby

Features:

- HD @720P
- Streaming View
- Self Testing
- Elite PI Designer software
- Elite PI Transfer software
- MICRO COMM serial link input

TO ORDER - EX156W-A12X

"D" = HD DIGITAL SCREEN
 "A" = AUXILIARY PANEL LINK

<BLANK> = LANDSCAPE
 "P" = PORTRAIT

RELATED DRAWINGS	
DESCRIPTION	DRAWING NAME
PANEL PREP.	PP156W-AI2
DETAIL DIM.	DD156W-AI2

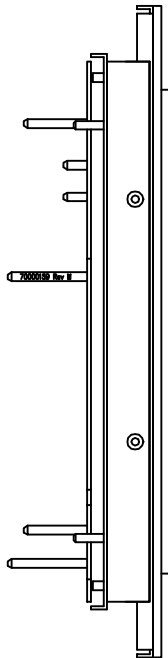
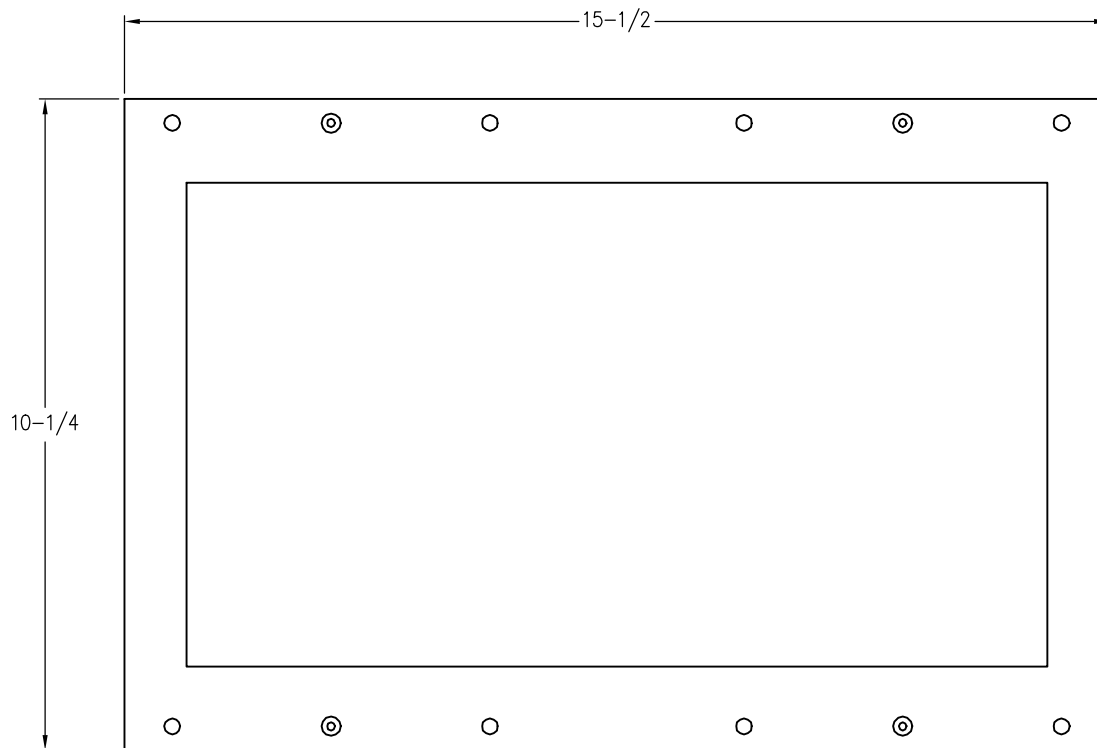
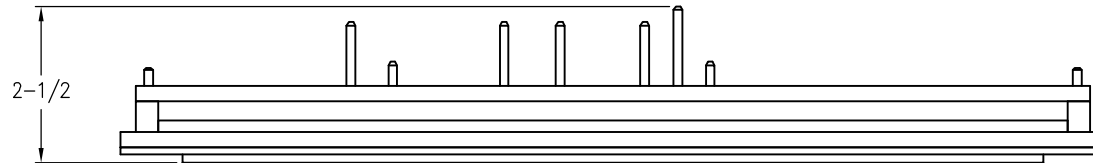

LENS NUMBER:	BOARD # & REV:
APPROVED BY:	
Signature:	
Date:	
Company:	

DATE DRAWN: 12/15/2022	LAST DATE REVISED	SCALE NTS	PART #
DRAWN BY: DJR	TOLERANCE UNLESS OTHERWISE SPECIFIED:		 C.E. ELECTRONICS, INC. 2107 Industrial Drive Bryan, Ohio 43506 (419) 636-6705
REQUESTED BY: RNT	TOLERANCE FOR CUTOFF (WINDOW):		
TITLE: EX156W-AI2 DIMENSIONAL DATA			DWG. NO. DD156W-AI2
			REV:

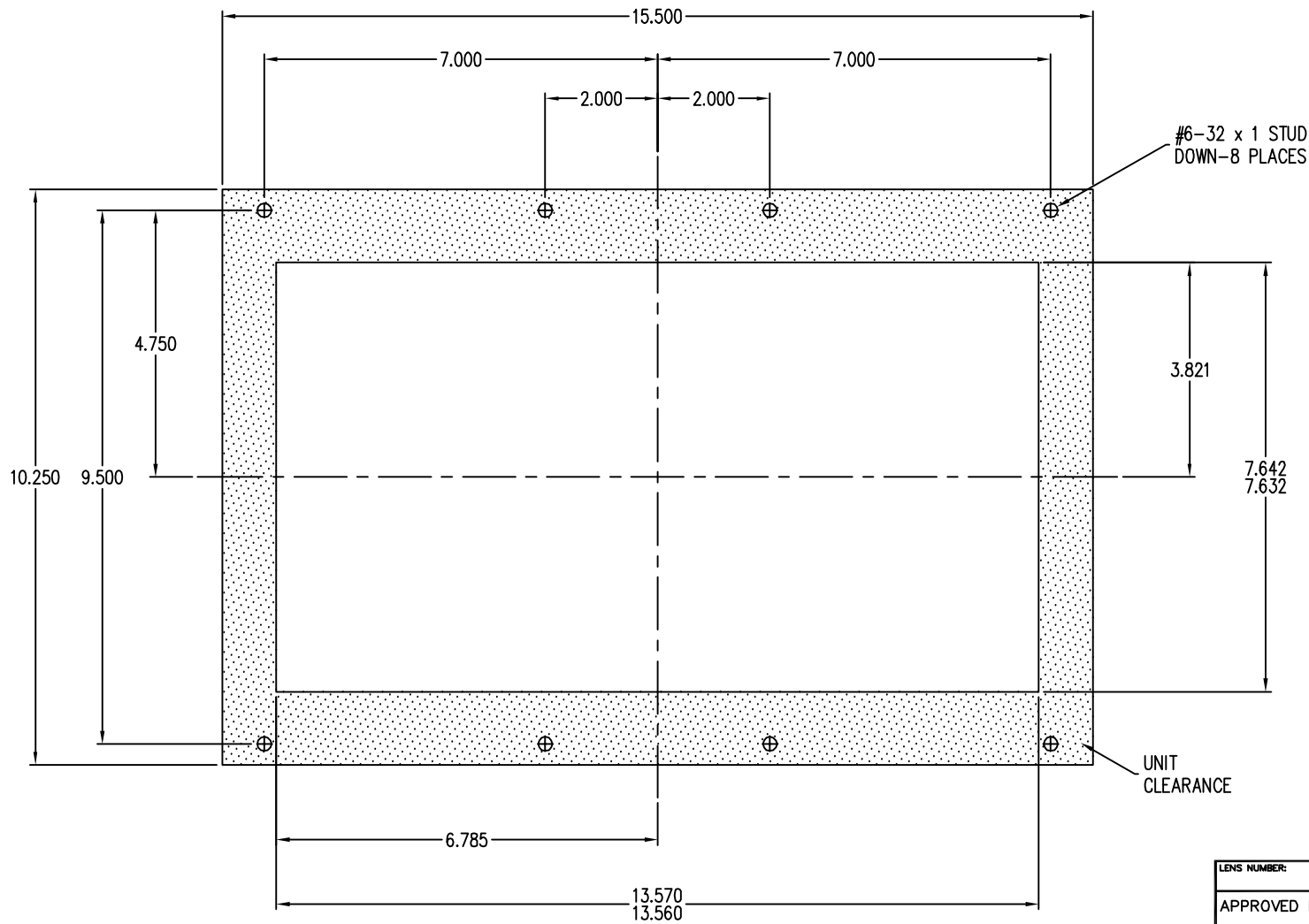

3-1/4 UNIT DEPTH

LENS NUMBER:	BOARD # & REV:
APPROVED BY:	
Signature:	
Date:	
Company:	

DATE DRAWN: 12/15/2022	LAST DATE REVISED	SCALE NTS	PART #
DRAWN BY: DJR	TOLERANCE UNLESS OTHERWISE SPECIFIED: ±.010		 C.E. ELECTRONICS, INC. 2107 Industrial Drive Bryan, Ohio 43506 (419) 636-6705
REQUESTED BY:	TOLERANCE FOR CUTOUT (WINDOW):		
TITLE: 15.6W PANEL PREP		DWG. NO. PP156W-AI2	REV: