

# ETKYPD-XXXX

KEYPAD FOR ELITE TOUCH



## ELITE TOUCH®

KEYPAD FOR ELITE TOUCH

The keypad is part of our Elite Touch product line to maintain code compliance where pushbuttons are still necessary, as well as provide a back up in the event the touchscreens are out of service.

### TYPICAL APPLICATIONS:

- > Car Operating Panel

### FEATURES:

- > Stainless Steel keys
- > 16mm high characters
- > 8 ohm Speaker

### METAL OPTION:



**C.E. Electronics, Inc. (US)** 2107 Industrial Drive, Bryan, Ohio 43506 p: 419.636.6705 [www.ceelectronics.com](http://www.ceelectronics.com)

**C.E. Electronics, Ltd. (UK)** P.O. Box 1679 Marlow, Bucks SL7 3ZG, UK p: +44 (0) 1628 487633 [www.ceelectronics.co.uk](http://www.ceelectronics.co.uk)

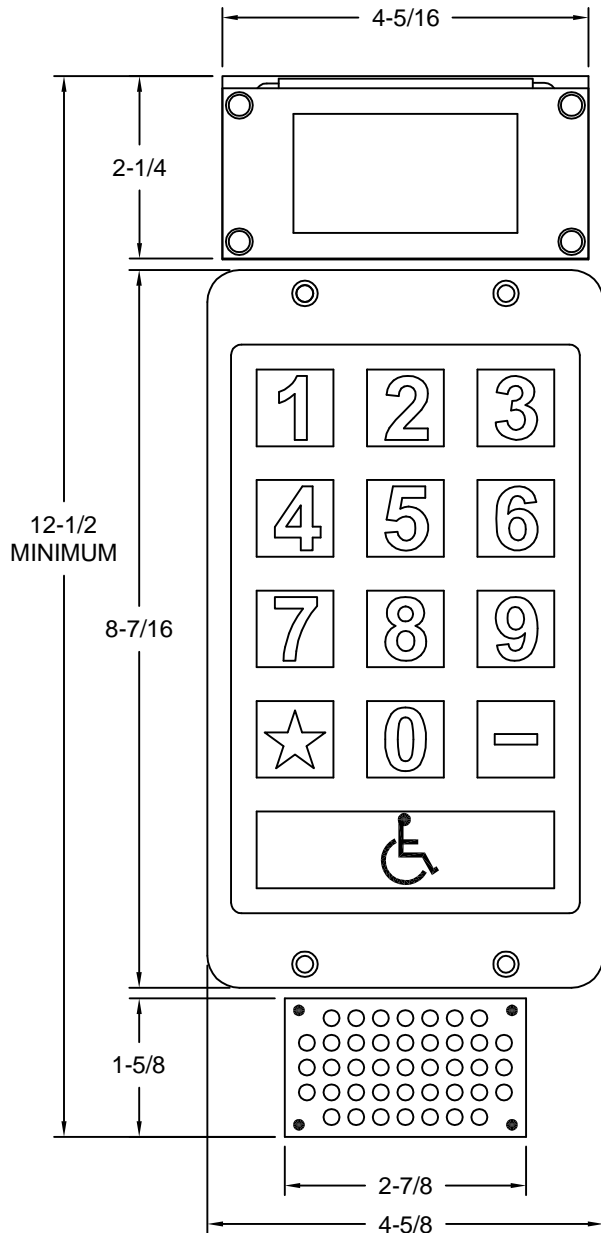

DISPLAY

KEYPAD

SPEAKER

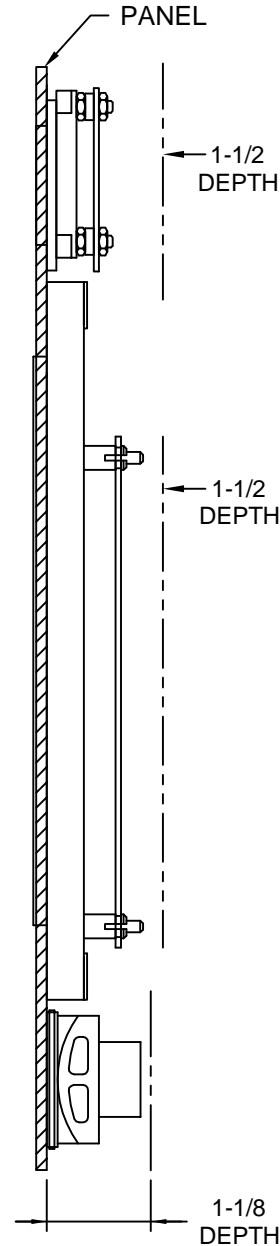

### Keypad for Elite Touch<sup>®</sup>

The keypad is part of our Elite Touch<sup>®</sup> product line to maintain code compliance where pushbuttons are still necessary, as well as provide a back up in the event the touchscreens are out of service.

#### Typical Applications

- Car Operating Panel

#### Features:

- Stainless Steel keys
- 16mm high characters
- 8 ohm Speaker

#### NOTE:

Maximum distance from keypad for display and speaker is 10 inches

For use with Elite Touch<sup>®</sup> units  
 Power Supply # 40102412 with  
 Bracket # 70000280 is recommended

### TO ORDER: - ETKYPD - X X X X

#### DISPLAY:

"D" = YES

"X" = NO

#### SPEAKER:

"S" = YES

"X" = NO

#### POWER INPUT: \*

"P" = POWER SUPPLY

"N" = NO POWER SUPPLY

#### KEYPAD STYLE:

"A" = MAIN - SILVER

"B" = MAIN - BLACK

"C" = AUXILIARY - SILVER

"D" = AUXILIARY - BLACK

\* If using CIB-O no Power Supply is required or if 24VDC is available in the COP no Power Supply is required.

NOTE: Templates available for specific mounting dimensions.

**KEYPAD CUT OUT AND STUD DETAIL**

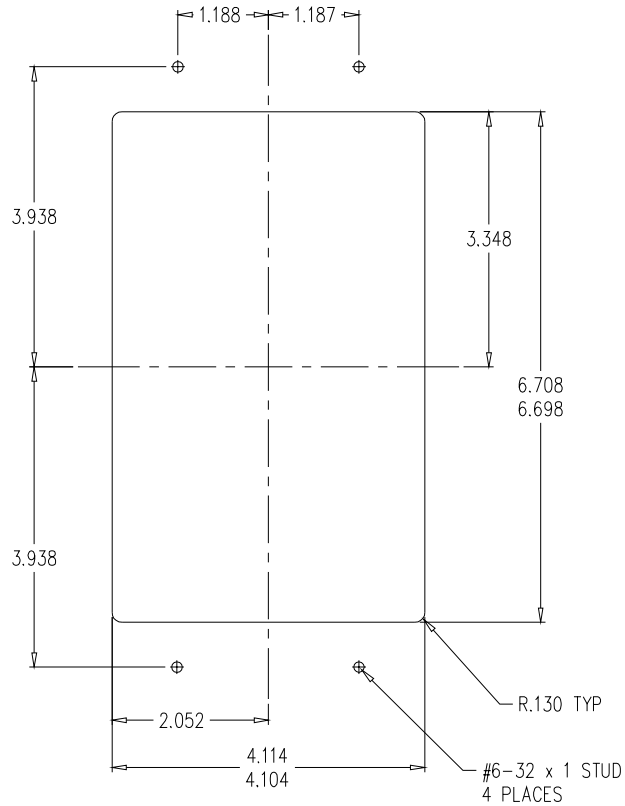

**SPEAKER CUT OUT AND STUD DETAIL**

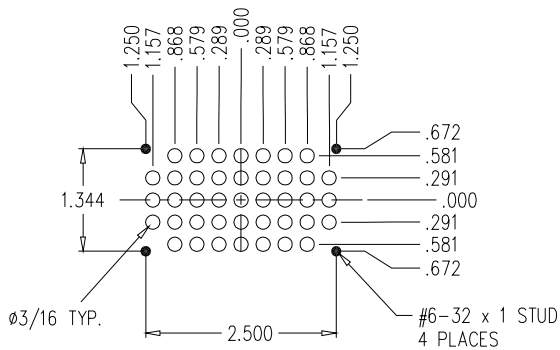

**DISPLAY CUT OUT AND STUD DETAIL**

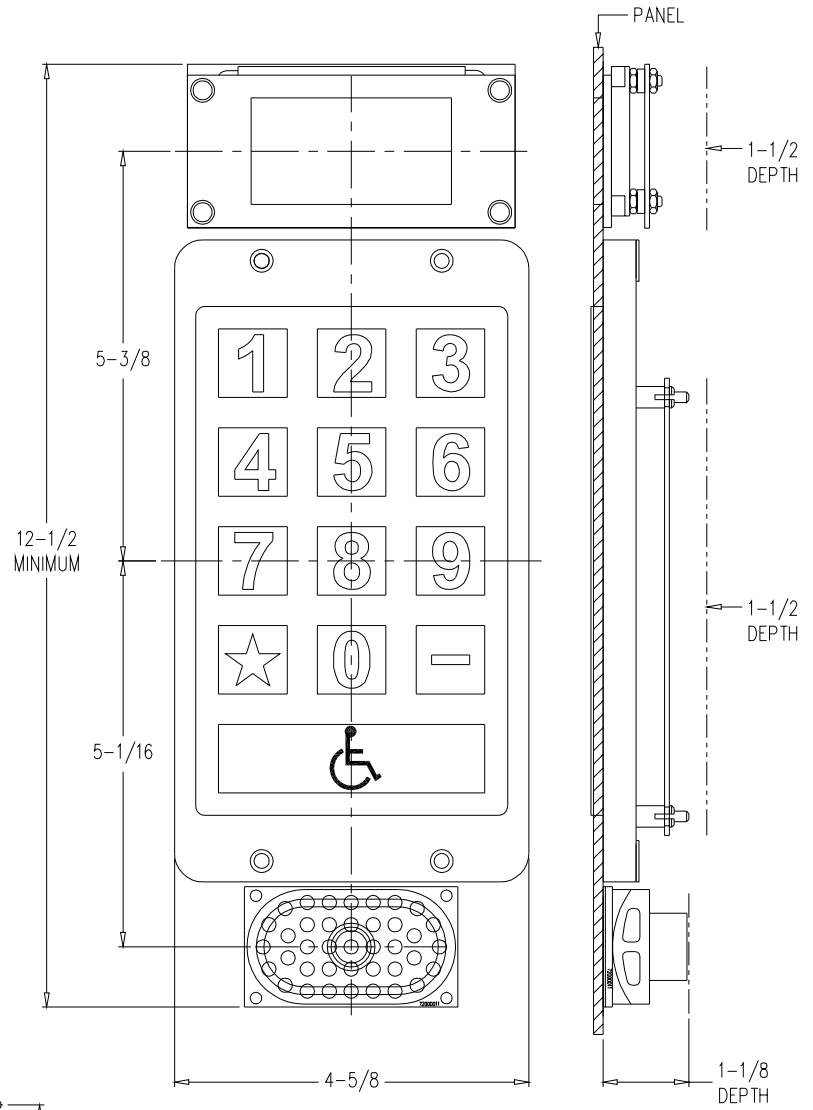
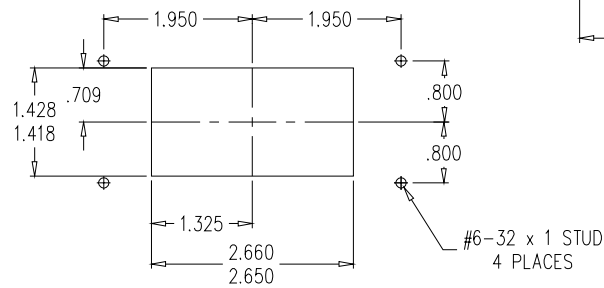

LENS NUMBER:	BOARD # & REV:
APPROVED BY:	
Signature: _____	
Date: _____	
Company: _____	

DATE DRAWN: 7/09/2015	LAST DATE REVISED 1/27/2017	SCALE NTS	PART #
DRAWN BY: DWS	TOLERANCE UNLESS OTHERWISE SPECIFIED: $\pm .010$		C.E. ELECTRONICS, INC. 2107 Industrial Drive Bryan, Ohio 43506 (419) 636-6705
REQUESTED BY:	TOLERANCE FOR CUTOUT (WINDOW):		
TITLE: KEYPAD / DISPLAY / SPEAKER PANEL PREP			DWG. NO. ETKYPD-PP REV. E