

> DV310-XXXXX

DOT MATRIX LED DIGITAL INDICATOR

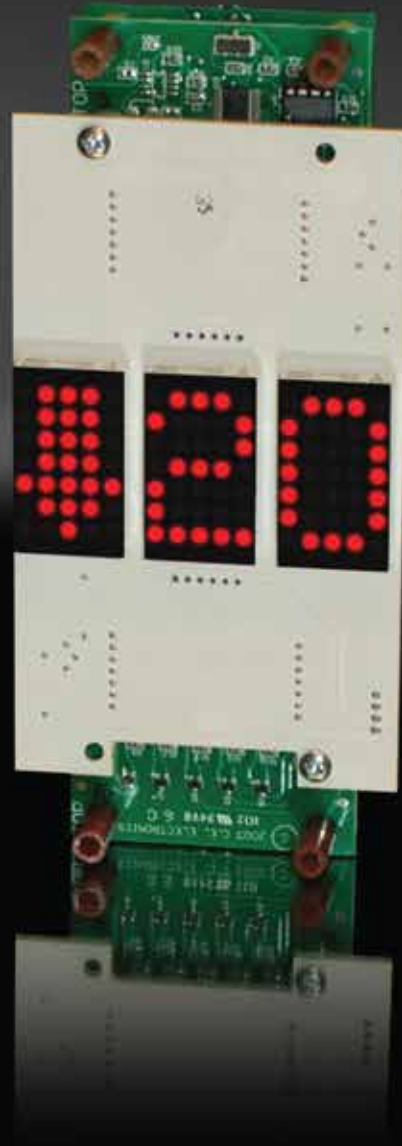

DOT MATRIX

1" CHARACTERS

Dot Matrix LED digital indicator for floor position display, as well as car direction, if desired. Any alphanumeric or custom character can be displayed in either single digit with separate "UP" and "DOWN" arrows. Double digit with single "UP/DOWN" arrow, or triple digit floor designations with no arrows.

TYPICAL APPLICATIONS:

- > Hall stations
- > Jamb mount

FEATURES:

- > Low cost design
- > Self contained unit
- > Latched input
- > Self testing
- > Scrolling
- > Passing chime output
- > Error detection and correction feature
- > UL listed



C.E. Electronics, Inc. (US) 2107 Industrial Drive, Bryan, Ohio 43506 p: 419.636.6705 www.ceelectronics.com

C.E. Electronics, Ltd. (UK) P.O. Box 1679 Marlow, Bucks SL7 3ZG, UK p: +44 (0) 1628 487633 www.ceelectronics.co.uk



C.E. Electronics, Inc.
 2107 Industrial Drive
 Bryan, OH 43506
 PH (419) 636-6705 FX (419) 636-2516
 www.ceelectronics.com

DV310-XXXXX

Ver. 8 Rel. 8/7/2015

COMPETITOR
 DOT MATRIX

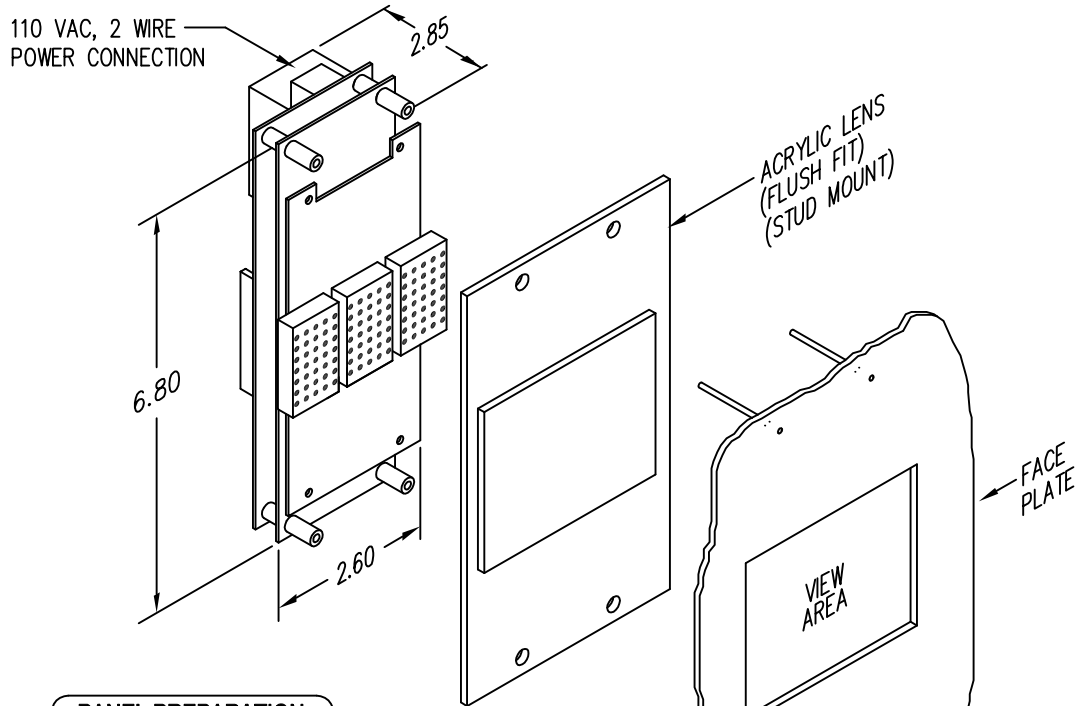

PANEL PREPARATION

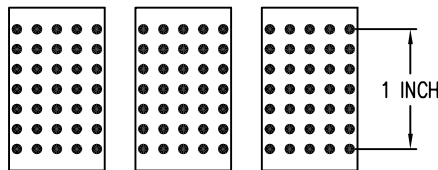
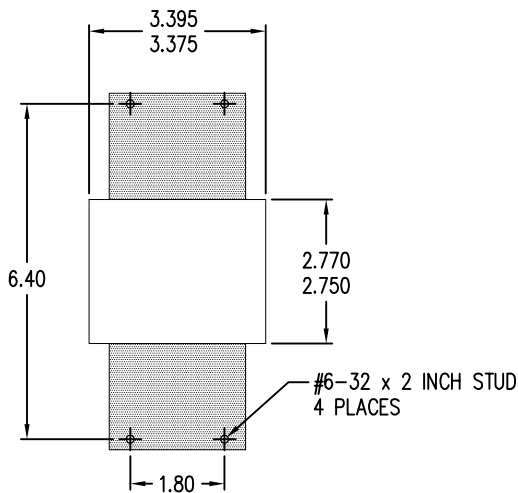

1 INCH CHARACTERS

DOT MATRIX LED DIGITAL INDICATOR

Dot matrix LED digital indicator for floor position display, as well as car direction, if desired. Any alphanumeric or custom character can be displayed in either single digit with separate "UP" and "DOWN" arrows. Double digit with single "UP/DOWN" arrow, or triple digit floor designations, with no arrows.

Typical Applications

- Hall stations
- Jamb mount

Features

- Low cost design
- Self contained unit
- Latched input
- Self testing
- Scrolling
- Passing chime output
- Error detection and correction feature
- UL listed

RENEWAL PARTS

RED Lens: # 104-3014
 GRAY Lens # 104-6108
 BLUE Lens # 104-9108

TO ORDER: SPECIFY DV310 - X X X X X

COLOR:

"0" = MIXED
 "R" = RED
 "A" = AMBER
 "G" = GREEN
 "W" = WHITE
 "B" = BLUE

NUMBER OF INPUTS:

"0" = 16 INPUT OR LESS
 "1" = 31 INPUT
 "M" = MICRO COMM

110VAC NOT REQUIRED
 FOR POWER SUPPLY
 ON MICRO COMM UNITS

LENS:

"R" = RED
 "G" = GRAY
 "B" = BLUE
 "X" = NO LENS

SIGNAL FORMAT:

"1" = SINGLE LINE/FLOOR
 "2" = BINARY
 "3" = UNITS & TENS
 "4" = GRAY CODE
 "5" = INVERTED BINARY
 "6" = SPECIAL
 "X" = IF MICRO COMM

SIGNAL VOLTAGE:

"A" = POSITIVE 6-20VDC, 6-24VAC
 "B" = POSITIVE 24-48VDC, 24-48VAC
 "C" = 120VAC
 "D" = POSITIVE 125VDC
 "E" = NEGATIVE 6-20VDC
 "F" = NEGATIVE 24-48VDC
 "G" = NEGATIVE 125VDC
 "X" = IF MICRO COMM
 PLEASE CONSULT FACTORY
 FOR SPECIAL VOLTAGE

DVXX0-XM

JOB# _____

S3 DIP SWITCH DETAIL

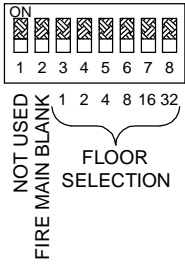

S3 DEFAULT SETTINGS

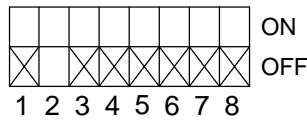

ROTARY SWITCH S1 _____

DRIVER BOARD# _____

CODE VERSION _____

DISPLAY BOARD# _____

CODE VERSION _____

FLOORS: _____

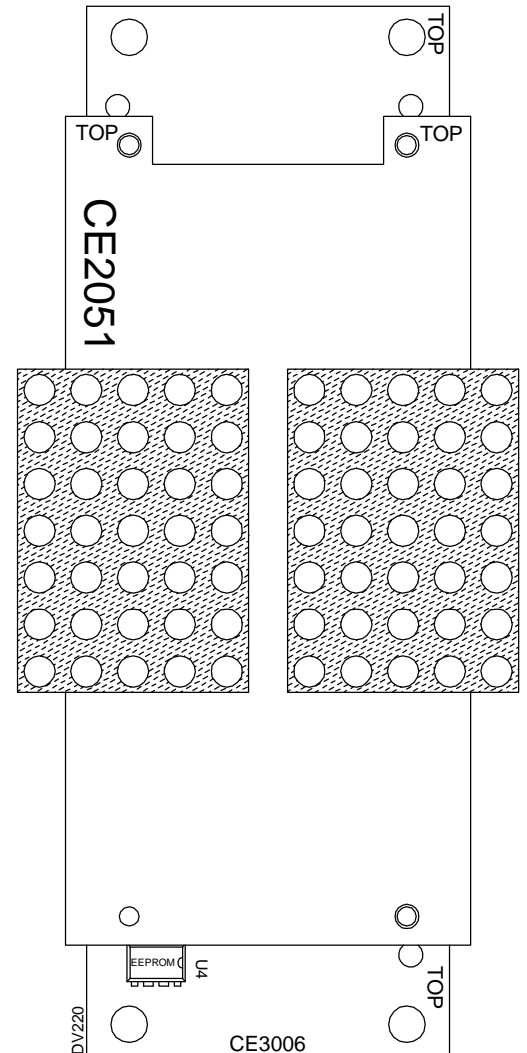
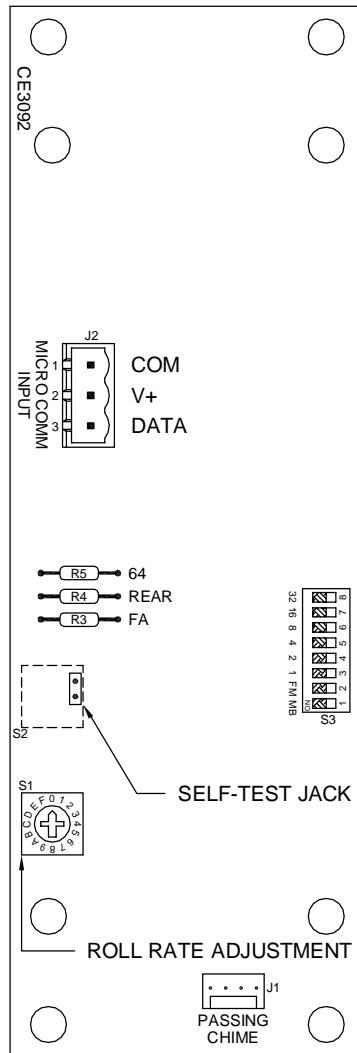

To SELF-TEST display unit, short the two pins on the S2 header and release.

NOTE: If S2 is a rotary switch, set it to "F" and back to 0 to self-test.

DIP switch 1 (MB) has no function with this unit.

The Micro Comm driver must be programmed to send messages with the level required to activate the features listed below.

- To blank the display during a fire main (level three) message, turn on DIP switch 2 (FM).
- To blank the display during a fire alternate (level two) message, remove resistor R3 (FA) from the board.
- Do not program a floor value for Floor 63 if the Fire Blanking feature is required.

DIP switches 3-8 off is an all call using travel signals. DIP switches 3-8 on and resistor R5 (64) removed is an all call using arrival signals.

The floor address switches setup the display arrows as arrival (hall) arrows. Refer to the "S3 DIP SWITCH DETAIL" and turn on the floor address switches whose value adds up to the desired floor. For example, to display the arrows only when the unit is at floor 19, turn on switches 3, 4, and 7 (values 1, 2, and 16: 1+2+16=19). The Micro Comm driver must be set up to send arrival information.

To operate this unit as a rear lantern, remove resistor R4 (REAR) from the board. NOTE: The Micro Comm driver must be sending the MC2000 data stream to use this feature. Call Tech Support at 419-636-6705 for more information.

NOTE: MUST BE USED WITH A CLASS 2 POWER SUPPLY.

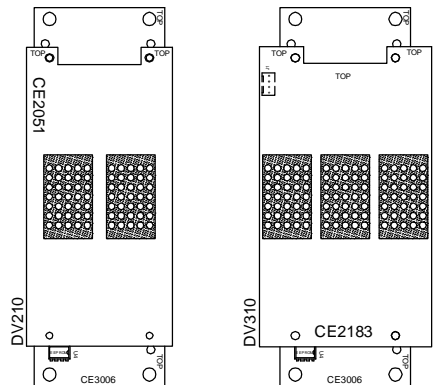

DATE DRAWN: 07/11/05	DRAWN BY: DAC	REQUESTED BY: DV	C.E. ELECTRONICS, INC. 2107 Industrial Drive Bryan, Ohio 43006 (419) 636-6705
BOARD NUMBER: 3092, 3006	LAST DATE REVISED: 02/01/07	APPROVED BY:	
PRODUCT: DVXXX-XM VERTICAL DOT MATRIX DISPLAY DWG. NO: DVXXX-XM_01 REV: A			

JOB# _____

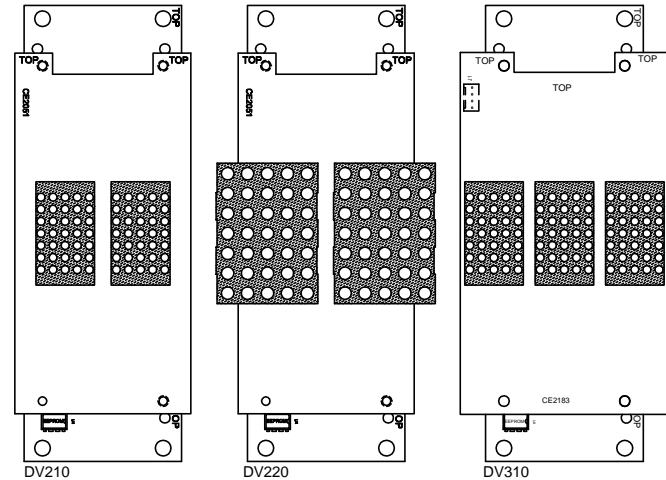
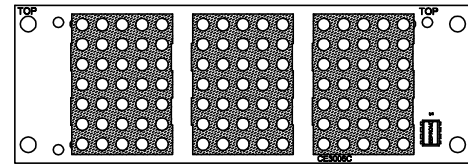
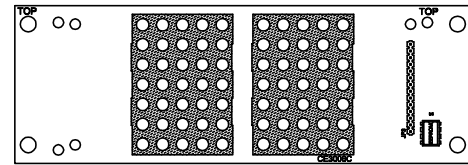
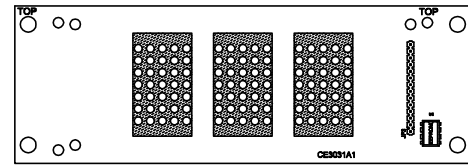
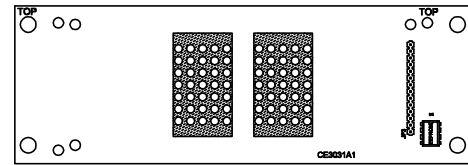

SCROLL RATE:
 0 = NO SCROLL
 1 = FAST SCROLL
 F = SLOW SCROLL

SELF-TEST JACK:
 SHORT PINS TO TEST
 SHORT PINS TO STOP TEST

OPTIONAL CHIME PORT

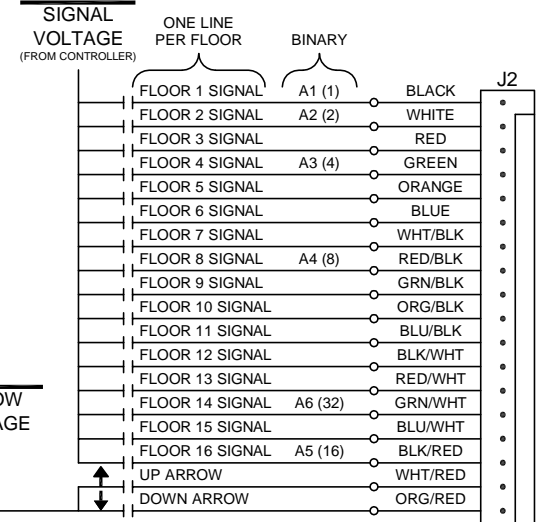
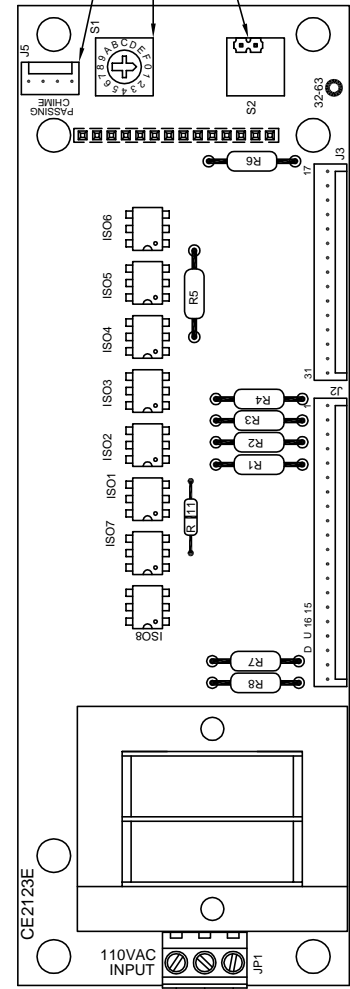

ONLY USED FOR ONE LINE PER FLOOR ABOVE 16 FLOORS

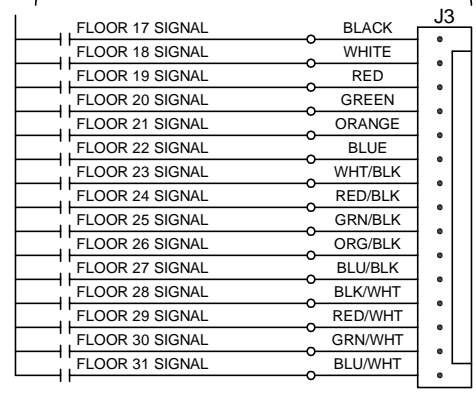

SEE NOTE () BELOW

NOTE A: THE SIGNAL AND ARROW COMMONS ARE TIED TOGETHER ON THE DRIVER BOARD. IF ARROW SOURCE IS DIFFERENT THAN SIGNAL SOURCE, CONTACT TECH SUPPORT AT 419-636-6705 FOR FURTHER INFORMATION.

NOTE B: THE SIGNAL AND ARROW COMMONS HAVE BEEN SEPARATED BY THE FACTORY.

DRIVER BOARD CE2123 _____

VERT DISPLAY BOARD CE _____ ROTARY SWITCH S1 _____

HORIZ DISPLAY BOARD CE _____ CODE VERSION _____

Competitor Series

Discrete Input Dot Matrix Displays

DATE DRAWN: 04/24/07	DRAWN BY: DAC	REQUESTED BY: DV	C.E. ELECTRONICS, INC. 2107 Industrial Drive Bryan, Ohio 43306 (419) 636-6705
BOARD NUMBER: 2123	LAST DATE REVISED: -	APPROVED BY:	
PRODUCT DISCRETE DOT MATRIX DISPLAYS			
DWG. NO. DM_2123_3006_3031			REV: -

BINARY FLOOR CHART

BINARY BITS

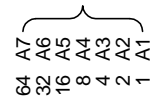

1000000 _____			
0111111 _____	0101111 _____	0011111 _____	0001111 _____
0111110 _____	0101110 _____	0011110 _____	0001110 _____
0111101 _____	0101101 _____	0011101 _____	0001101 _____
0111100 _____	0101100 _____	0011100 _____	0001100 _____
0111011 _____	0101011 _____	0011011 _____	0001011 _____
0111010 _____	0101010 _____	0011010 _____	0001010 _____
0111001 _____	0101001 _____	0011001 _____	0001001 _____
0111000 _____	0101000 _____	0011000 _____	0001000 _____
0110111 _____	0100111 _____	0010111 _____	0000111 _____
0110110 _____	0100110 _____	0010110 _____	0000110 _____
0110101 _____	0100101 _____	0010101 _____	0000101 _____
0110100 _____	0100100 _____	0010100 _____	0000100 _____
0110011 _____	0100011 _____	0010011 _____	0000011 _____
0110010 _____	0100010 _____	0010010 _____	0000010 _____
0110001 _____	0100001 _____	0010001 _____	0000001 _____
0110000 _____	0100000 _____	0010000 _____	0000000 _____

INSTALLATION GUIDE

1. MAKE SURE THE INPUT RESISTORS ARE FULLY SEATED IN THEIR SOCKETS.
2. CONNECT 115VAC TO THE OUTER TERMINALS OF CONNECTOR J1. THE CENTER TERMINAL HAS NO CONNECTION.
3. SHORT THE TWO PINS OF S2 (TEST JACK) TOGETHER. THE DISPLAY WILL CYCLE THROUGH THE FLOOR DATA. THIS SHOWS WHAT FLOOR MARKINGS WILL BE DISPLAYED AND ALLOWS ADJUSTMENT OF THE SCROLL RATE AND OPTIONAL PASSING CHIME VOLUME.
4. MAKE SURE THE SIGNAL CABLE(S) IS PLUGGED INTO THE DRIVER BOARD CORRECTLY.
5. CONNECT THE SIGNAL CABLE(S) TO THE CONTROLLER. THE VOLTAGE AND DC POLARITY ARE MARKED ON THE REVERSE SIDE. THE UNIT WORKS LIKE A LIGHT BULB; IT NEEDS VOLTAGE FROM COMMON TO THE SELECTED INPUT.
6. IF THE INPUT IS DC AND YOU SUSPECT THE POLARITY IS WRONG, PUT THE SELECTED FLOOR WIRE TO COMMON AND COMMON TO THE SELECTED FLOOR INPUT. IF THE UNIT DISPLAYS THE FLOOR, CONTACT TECH SUPPORT.
7. IF THE INPUT FORMAT IS SINGLE LINE PER FLOOR, ONLY ONE WIRE SHOULD HAVE VOLTAGE PRESENT (WITH REFERENCE TO COMMON) AT ANY TIME.
8. IF THE UNIT DOES NOT SEEM TO WORK PROPERLY, RECHECK THE ABOVE STEPS. IF THE PROBLEM CONTINUES, RECORD THE SERIAL NUMBER FROM THE WHITE LABEL ON THE UNIT AND EXACTLY WHAT THE UNIT DISPLAYS AT EACH FLOOR, THEN CONTACT TECH SUPPORT AT 419-636-6705.

DATE DRAWN: 04/24/07	DRAWN BY: DAC	REQUESTED BY: DV	 C.E. ELECTRONICS, INC. 2107 Industrial Drive Bryan, Ohio 43506 (419) 636-6705
BOARD NUMBER: N/A	LAST DATE REVISED: -	APPROVED BY:	
PRODUCT COMPETITOR SERIES BINARY FLOOR CHART			
DWG. NO. COMP_BINCHART_TJ			REV. -