

# > DV110-X0XXXX

## DOT MATRIX LED DIGITAL INDICATOR

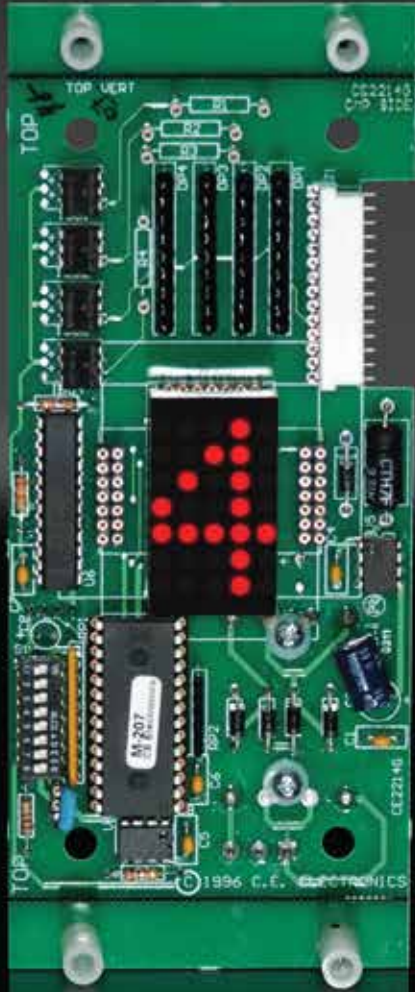

# DOT MATRIX

1" CHARACTER

Dot Matrix LED digital indicator for floor position display. Any alphanumeric or custom character can be displayed.

### TYPICAL APPLICATIONS:

- > Hall stations
- > Jamb mount

### FEATURES:

- > Low cost design
- > Self contained unit
- > Latched input
- > Self testing
- > 13 inputs
- > Passing chime output
- > Error detection and correction feature
- > UL listed



**C.E. Electronics, Inc.**  
C.E. Electronics, Ltd.  
International Lift Equipment (ILE)

2107 Industrial Drive Bryan, OH 43506  
Marlow, Bucks, UK  
Highams Park, London, UK

ph: 419.636.6705

ph: +44 (0) 1628 487633  
ph: 0208 527 9669

[www.cееlectronics.com](http://www.cееlectronics.com)

[www.cееlectronics.co.uk](http://www.cееlectronics.co.uk)  
[www.ileweb.com](http://www.ileweb.com)





C.E. Electronics, Inc.  
 2107 Industrial Drive  
 Bryan, OH 43506  
 PH (419) 636-6705 FX (419) 636-2516  
 www.ceelectronics.com

# DV110-X0XXXX

Ver. 5 Rel. 10/7/2013

COMPETITOR  
 DOT MATRIX

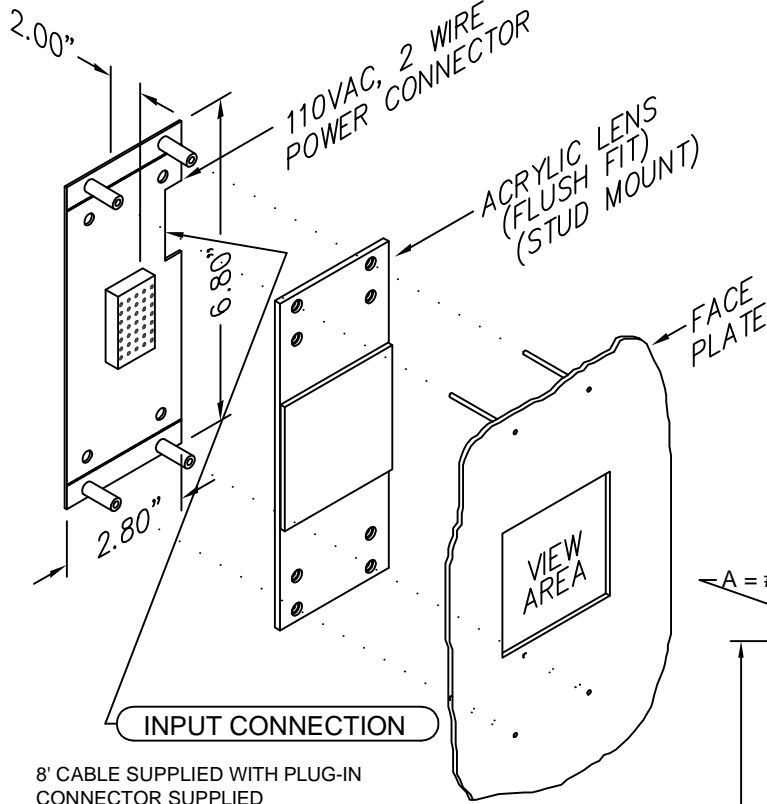

### RENEWAL PARTS

- Lens: 104-3011 RED
- Lens: 104-6019 GRAY
- Lens: 104-9019 BLUE

### PANEL PREPARATION

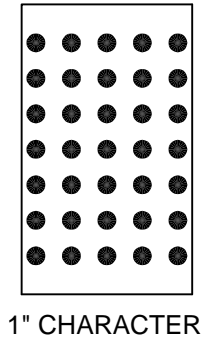
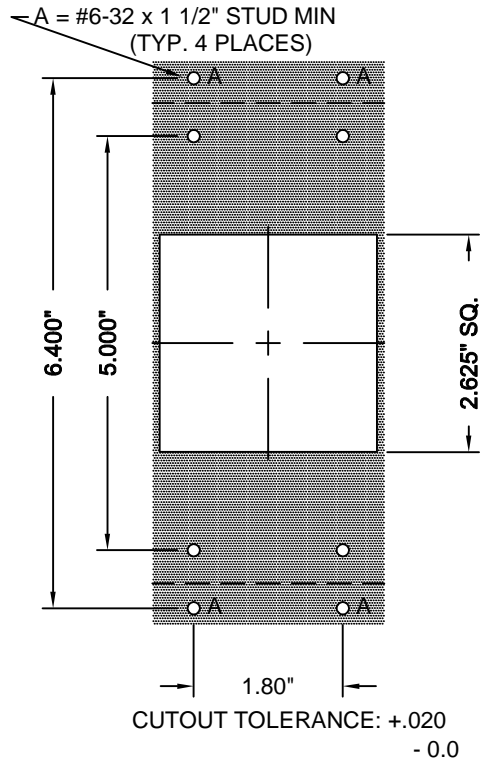

### DOT MATRIX LED DIGITAL INDICATOR

Dot matrix LED digital indicator for floor position display. Any alphanumeric or custom character can be displayed.

### Typical Applications

- Hall stations
- Jamb mount

### Features

- Low cost design
- Self contained unit
- Latched input
- Self testing
- 13 inputs
- Passing chime output
- Error detection and correction feature
- UL listed

TO ORDER: -SPECIFY DV110 - X 0 X X X

COLOR:  
 "R" = RED  
 "A" = AMBER  
 "G" = GREEN  
 "W" = WHITE  
 "B" = BLUE

LENS:  
 "R" = RED  
 "G" = GRAY  
 "B" = BLUE  
 "X" = NO LENS

NUMBER OF INPUTS:  
 "0" = 13 INPUT OR LESS

SIGNAL FORMAT:  
 "1" = SINGLE LINE/FLOOR  
 "2" = BINARY  
 "3" = UNITS & TENS  
 "4" = GRAY CODE  
 "5" = INVERTED BINARY  
 "6" = SPECIAL

SIGNAL VOLTAGE:  
 "A" = POSITIVE 6-20VDC, 6-24VAC  
 "B" = POSITIVE 24-48VDC, 24-48VAC  
 "C" = 120VAC  
 "D" = POSITIVE 125VDC  
 "E" = NEGATIVE 6-20VDC  
 "F" = NEGATIVE 24-48VDC  
 "G" = NEGATIVE 125VDC

### NOTE:

- If a special voltage is required, please consult factory.

# SINGLE-DIGIT DOT MATRIX DISPLAY

DH110, DV110, DH120, DV120, DH130, DV130

JOB# \_\_\_\_\_

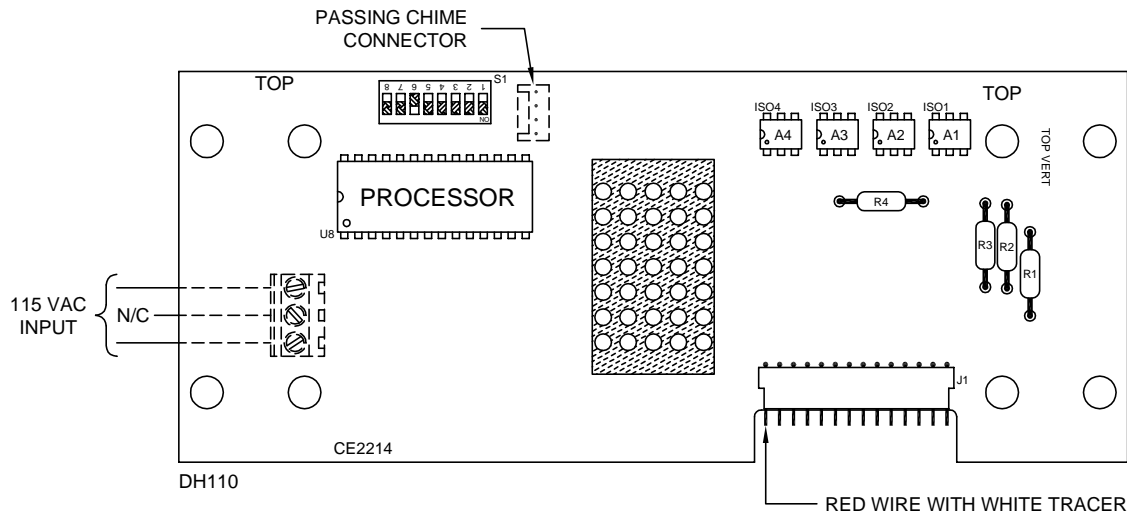

NOTE: PASSING CHIME CONNECTOR AND POWER CONNECTION ARE ON THE BACK OF THE BOARD.

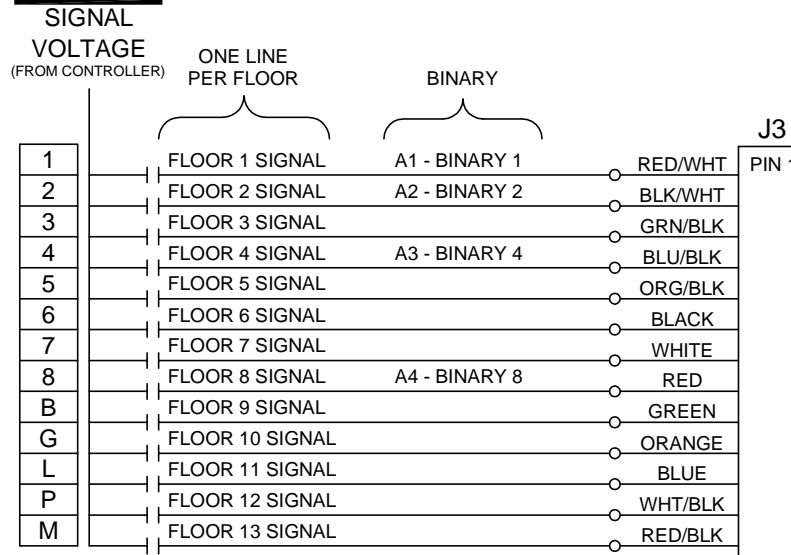
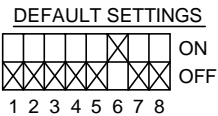
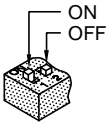
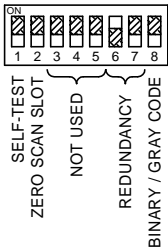
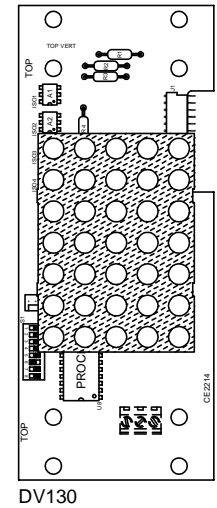
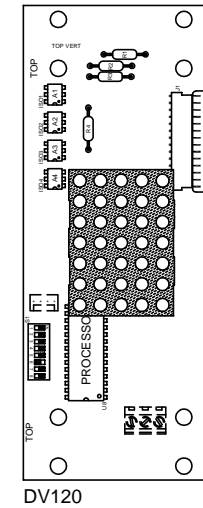
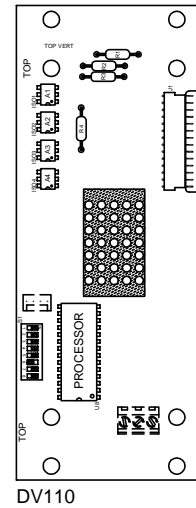

STD  CUSTOM

FLOOR MARKINGS

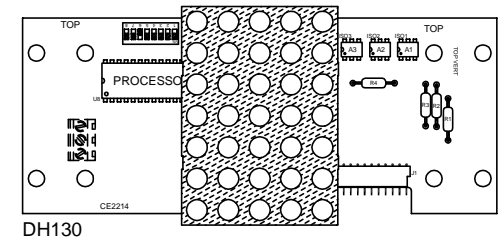
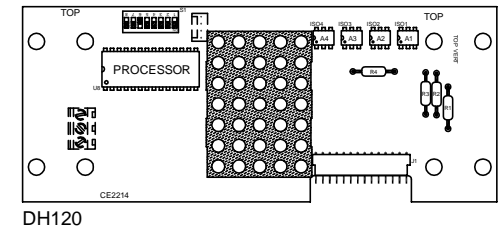

CODE VERSION \_\_\_\_\_

BOARD VERSION CE2214 \_\_\_\_\_

NOTE: IF FORMAT IS BINARY OR GRAY CODE, SEE CHART ON BACK!

DATE DRAWN: 08/29/05	DRAWN BY: DAC	REQUESTED BY: DAC	<p>C.E. ELECTRONICS, INC. 2107 Industrial Drive Bryan, Ohio 43006 (419) 636-6705</p>
BOARD NUMBER: 2214	LAST DATE REVISED: 04/18/11	APPROVED BY:	
PRODUCT: SINGLE-DIGIT DM DISPLAY			
			<p>DWG. NO. DM-SINGLE_01</p> <p>REV. B</p>

## BINARY FLOOR CHART

Standard Floor Markings	Custom Floor Markings
BINARY BITS A4 - BIN 1 A3 - BIN 1 A2 - BIN 1 A1 - BIN 1 1 1 0 1 <u>    </u> M 1 1 0 0 <u>    </u> P 1 0 1 1 <u>    </u> L 1 0 1 0 <u>    </u> G 1 0 0 1 <u>    </u> B 1 0 0 0 <u>    </u> 8 0 1 1 1 <u>    </u> 7 0 1 1 0 <u>    </u> 6 0 1 0 1 <u>    </u> 5 0 1 0 0 <u>    </u> 4 0 0 1 1 <u>    </u> 3 0 0 1 0 <u>    </u> 2 0 0 0 1 <u>    </u> 1	BINARY BITS A4 - BIN 1 A3 - BIN 1 A2 - BIN 1 A1 - BIN 1 1 1 0 1 <u>    </u> 1 1 0 0 <u>    </u> 1 0 1 1 <u>    </u> 1 0 1 0 <u>    </u> 1 0 0 1 <u>    </u> 1 0 0 0 <u>    </u> 0 1 1 1 <u>    </u> 0 1 1 0 <u>    </u> 0 1 0 1 <u>    </u> 0 1 0 0 <u>    </u> 0 0 1 1 <u>    </u> 0 0 1 0 <u>    </u> 0 0 0 1 <u>    </u>

## GRAY CODE FLOOR CHART

Standard Floor Markings	Custom Floor Markings
GRAY CODE BITS A4 - BIN 1 A3 - BIN 1 A2 - BIN 1 A1 - BIN 1 1 0 1 1 <u>    </u> M 1 0 1 0 <u>    </u> P 1 1 1 0 <u>    </u> L 1 1 1 1 <u>    </u> G 1 1 0 1 <u>    </u> B 1 1 0 0 <u>    </u> 8 0 1 0 0 <u>    </u> 7 0 1 0 1 <u>    </u> 6 0 1 1 1 <u>    </u> 5 0 1 1 0 <u>    </u> 4 0 0 1 0 <u>    </u> 3 0 0 1 1 <u>    </u> 2 0 0 0 1 <u>    </u> 1	GRAY CODE BITS A4 - BIN 1 A3 - BIN 1 A2 - BIN 1 A1 - BIN 1 1 0 1 1 <u>    </u> 1 0 1 0 <u>    </u> 1 1 1 0 <u>    </u> 1 1 1 1 <u>    </u> 1 1 0 1 <u>    </u> 1 1 0 0 <u>    </u> 0 1 0 0 <u>    </u> 0 1 0 1 <u>    </u> 0 1 1 1 <u>    </u> 0 1 1 0 <u>    </u> 0 0 1 0 <u>    </u> 0 0 1 1 <u>    </u> 0 0 0 1 <u>    </u>

### INSTALLATION GUIDE

1. Make sure the input resistors are pushed all the way into the sockets.
2. Connect 115VAC power to the outer terminals of J2. Nothing connects to the center terminal.
3. To use the optional passing chime, connect it to J3.
4. Turn on DIP switch 1 (self-test). The display cycles through the floor markings. Verify the floor markings are correct and adjust the volume of the optional passing chime.
5. Connect the signal cable to J1 on the display. Be sure to install the cable properly (red wire with white tracer positioned as shown on the other side of this page).
6. Use the diagram on the other side of this page to connect the signal cable to the controller. The voltage (and DC polarity, if needed) are marked on the diagram. This unit works like a light bulb; it has to have voltage between common and the selected input.
7. If the input voltage is DC and you suspect the controller uses the opposite polarity, remove the common from the display and then put the selected floor wire to common and common to the selected floor input. If the selected floor displays, contact Tech Support at the number below.
8. For single line per floor set-ups, only one wire at a time can have voltage present (with reference to common).
9. If the display does not work properly after following the steps above, write down the serial number from the white label and exactly what the unit displays at each floor. Call Tech Support at (419) 636-6705.

DATE DRAWN: 05/05/97	DRAWN BY: K.L.S.	REQUESTED BY: J.P.	 C.E. ELECTRONICS, INC. 2107 Industrial Drive Bryan, Ohio 43506 (419) 636-6705
BOARD NUMBER: N/A	LAST DATE REVISED: 04/18/11	APPROVED BY:	
PRODUCT SINGLE DM FLOOR MARKINGS			
DWG. NO. COMPT-4			REV. C