



C.E. Electronics, Inc.
 2107 Industrial Drive
 Bryan, OH 43506
 PH (419) 636-6705 FX (419) 636-2516
 www.ceelectronics.com

DLMS1-D

Ver 2. Rel. 9/18/2023

ACCESSORIES

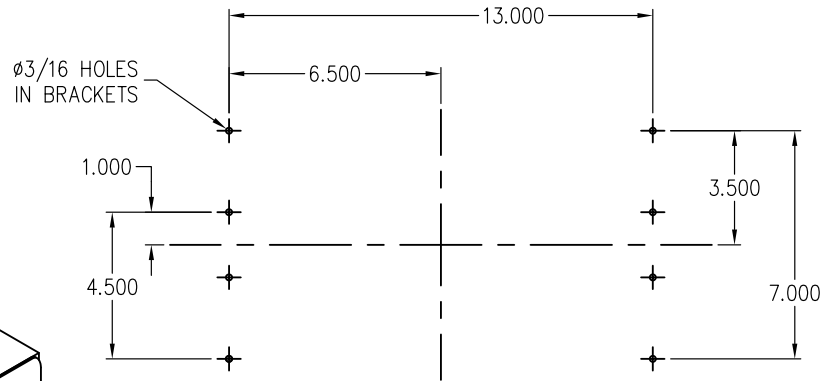
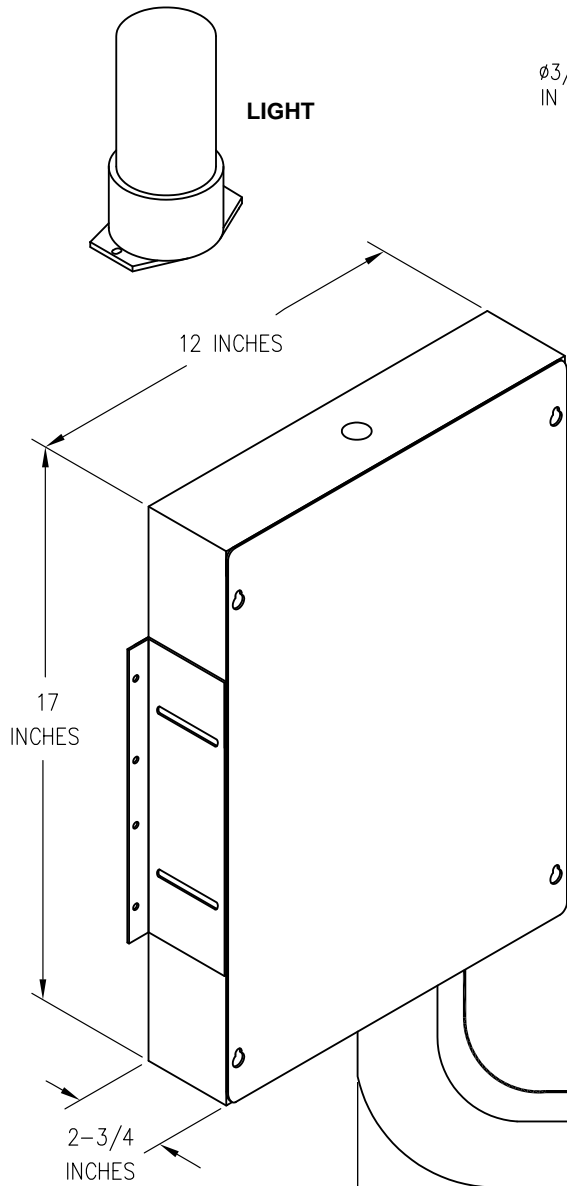

**DLMS1-D
MOUNTING DETAIL**

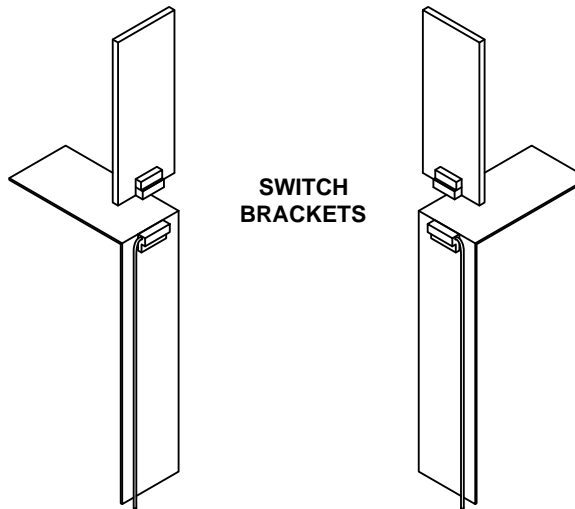

ELEVATOR CAB DOOR MONITORING EXISTING CODE REQUIRED SAFETY UPGRADE

A17.3* code requires that all existing elevators are equipped with an additional cab door monitoring system and logic. A17.3 code for existing elevators implements safety enhancements retroactively.

BENEFITS OF UPGRADE

- Enhances Safety for Riding Public
- Provides Code Required Operation
- Designed for Compatibility with Older Elevators

CAB DOOR MONITORING UPGRADE

- New Logic System & Boards
- New Cab Door Sensors
- New Power Supply
- New NEMA 1 Cabinet
- Updated Software/Logic
- Regulatory and A17.3 Compliance
- A17.3 Code Year 2015

TO ORDER: DLMS1-D

