

COVER PLATE

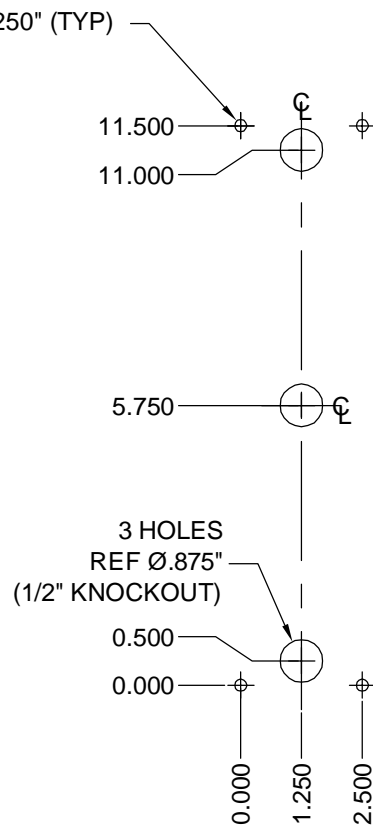

CUTOUT & STUD DETAIL

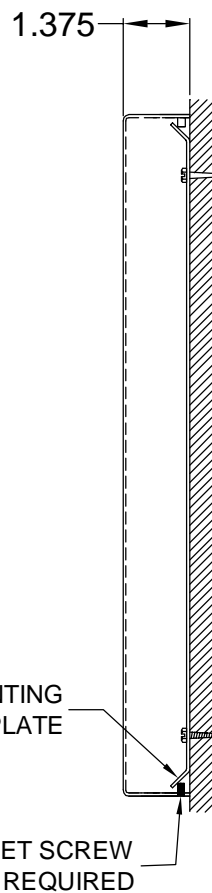
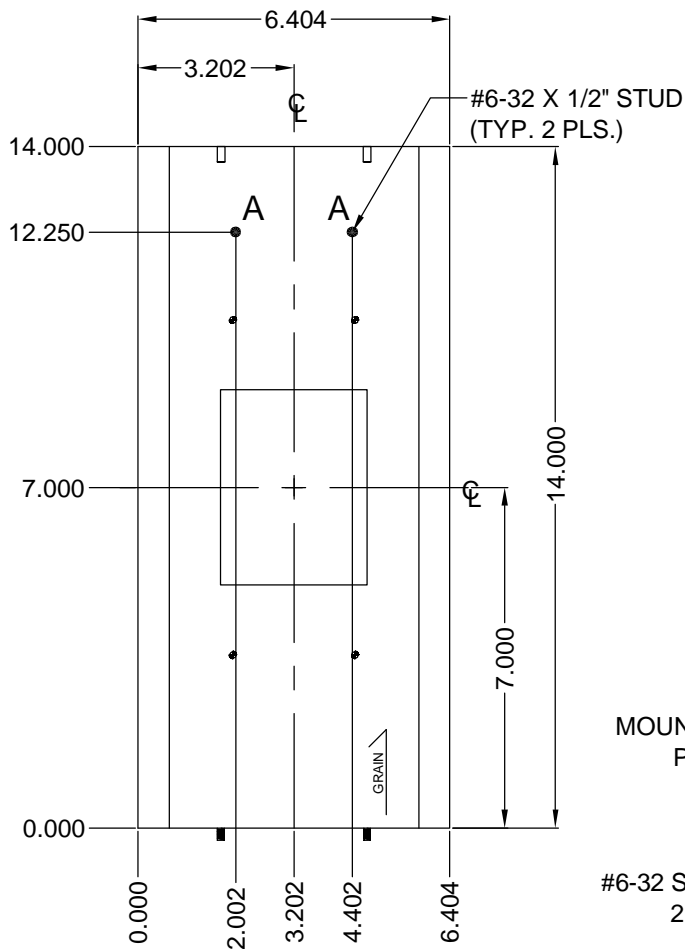
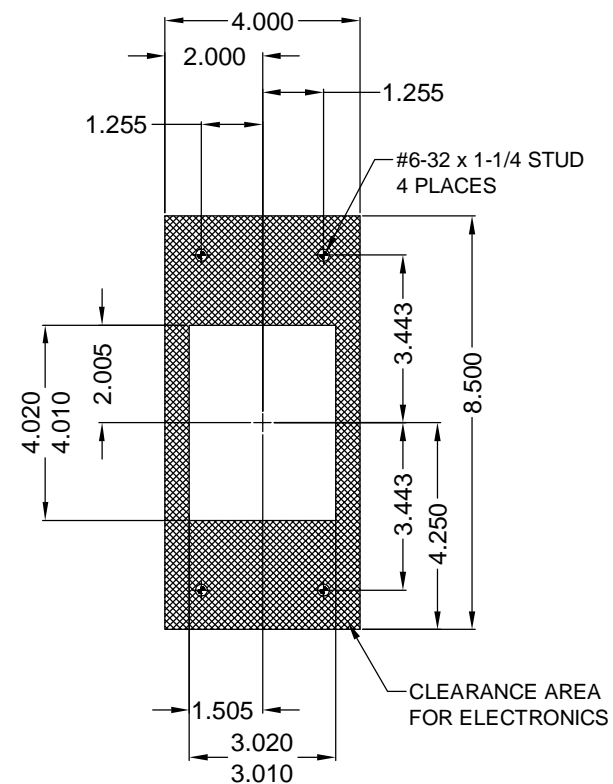

NOTE:
GRAY AREA IS BOARD CLEARANCE

CUT-OUT & MTG. DETAIL

MATERIAL: 16 GA (.060) STAINLESS STEEL
FINISH: #4 BRUSHED - VERTICAL GRAIN
NOTE: GALVANIZED BACK PLATE INCLUDED

LENS NUMBER:	BOARD # & REV:
APPROVED BY:	
Signature: _____	
Date: _____	
Company: _____	

DATE DRAWN: 6/10/09	LAST DATE REVISED: 8/25/2010	SCALE: NONE	PART #:
DRAWN BY: D.W.S.	TOLERANCE UNLESS OTHERWISE SPECIFIED: +0.015, -0.015		 C.E. ELECTRONICS, INC. 2107 Industrial Drive Bryan, Ohio 43506 (419) 636-6705
REQUESTED BY: G.L.C.	TOLERANCE FOR CUTOUT (WINDOW): +0.020, -0.000		
TITLE: FIXTURE SURFACE VERTICAL		DWG. NO. 70100144	REV. A